



**3731 Hamilton Street/3744 Old Columbia Pike, Ellicott City  
Minor Alteration Determination**

**AFTER 5 DAYS POSTING ON WEBSITE:**

<b>Written Objection WAS NOT Received:</b>	<b>Written Objection WAS Received:</b>	<b>Date Issued:</b>
<input type="checkbox"/> No written objection was received and the proposed work was determined to be a minor alteration, not requiring Commission approval.	<input type="checkbox"/> Yes, a written objection was received. A Certificate of Approval is required.	

**Executive Secretary Signature**

\_\_\_\_\_  
Beth Burgess, Executive Secretary                      Date  
Historic Preservation Commission

# HOWARD COUNTY HISTORIC PRESERVATION COMMISSION

## GENERAL APPLICATION FOR CERTIFICATE OF APPROVAL AND TAX CREDIT PRE-APPROVAL

**SUBMIT 10 COPIES** of this application package, including all supporting materials required on pages 2-5 of this application to Howard County Department of Planning and Zoning. Applications must be received no later than 5:00 pm 22 days prior to the meeting. Applications can be submitted via mail, but may result in missing the deadline. Applications are not accepted via email or fax.

Address: 3430 Court House Drive, Ellicott City, MD 21043

### Meeting Information

The Historic Preservation Commission (HPC) meets at 7:00 pm generally on the first Thursday of each month at 3430 Court House Dr., Ellicott City, MD. Please contact us regarding emergency applications.

### Questions

Please contact Samantha Holmes, Historic Preservation Planner at 410-313-4428 or [sholmes@howardcountymd.gov](mailto:sholmes@howardcountymd.gov).

### FOR STAFF USE ONLY

#### Application #:

HPC -

MA - **20-18**

#### Meeting Date:

**posted online**

#### Date Received:

**2/19/20**

### PROPERTY INFORMATION

Address of Subject Property: **3731 Hamilton St. Ellicott City, MD., 21043**

Name of Property Owner: **Susan Duff**

Historic District (please check):  Ellicott City Local Historic District  Lawyers Hill Local Historic District

Is this property listed on the Howard County Historic Sites Inventory?  Y  N #HO- \_\_\_\_\_

### APPLICANT INFORMATION

Name of Applicant (please only provide one name for contact purposes): **Veronica Daniel**

Mailing address: **P.O. Box 33044 Granada Hills, CA., 91394**

Phone No. (W) **330-459-0311** (H) \_\_\_\_\_

Email: **veronica.christine1@gmail.com** Contact Preference: **email**

### BELOW FOR STAFF USE ONLY

Tax Account Number: \_\_\_\_\_

Map \_\_\_\_\_ Parcel \_\_\_\_\_

## Part 1: General Application for Certificate of Approval

**ALL APPLICATIONS MUST INCLUDE:** The information required in this checklist must be provided or the application will be incomplete and may be rejected for consideration by the Commission. Please check each box below to confirm you have provided this information.

- Labeled, color photographs of existing property conditions, printed on 8.5x11 paper, no more than two images per page. Do not submit individual 4x6 photographs.
- A detailed description of the proposed work (include below or provide on a separate sheet of paper if more space is needed— do not add proposed work into the Guidelines justification section).
- Product specification sheets/photographs of product that clearly shows materials, colors, and dimensions.
- Plot plan of property, site plans, or elevations (as applicable to proposal; but required for any new construction).
- For major alterations: elevation drawings of proposed structure indicating dimensions, design, height, color, and materials. Product spec sheets are required for all new elements.
- A completed Part 2 of this application (page 3-4). Application may be rejected if not complete. If Part 2 is not suitable for your project, please type up a detailed explanation on a separate piece of paper.
- A completed Part 3 of this application (page 5) if you seek tax credits for any work.
- A completed Part 4 of this application (page 5). If the owner is not the applicant, the owner's signature is also required.
- I have read the Ellicott City or Lawyers Hill Design Guidelines and find my proposal complies with the recommendations in the Guidelines, as indicated below.

**DESCRIPTION OF PROPOSAL:** If more room is required, please provide write up on a separate sheet of paper to best organize proposed work. Continue to Part 2 (page 3-5) to complete required checklists.

To provide teak exterior seating and side tables that accompany the proposed fire pit. The furniture will fit within the proposed 15'x15' stone patio.

---

---

---

---

---

---

---

---

---

---

**DESIGN GUIDELINES:** Consult the Ellicott City or Lawyers Hill Design Guidelines on the Howard County website at <https://www.howardcountymd.gov/Departments/Planning-and-Zoning/Conservation-and-Preservation/Historic> and provide a brief description of how the proposal meets the recommendations of the Guidelines, including the applicable chapter and section. Please type up on a separate sheet of paper if more space is needed.

---

---

---

---

---

---

---

---

---

---

## Part 2: General Application for Certificate of Approval Checklist

TYPE OF ALTERATION: Please check the appropriate box for the proposed work and fill in required blanks. Specs sheets and photos must be provided or the application may be considered incomplete and rejected for consideration by the Commission.

You may create your own document if it better explains the project, be sure to include details such as materials and colors for all existing/previously existing and proposed features.

**DOORS AND STORMS DOORS:** Refer to page 35 of the Ellicott City Guidelines and pages 26-29 of the Lawyers Hill Guidelines.

Existing Type: \_\_\_\_\_

Proposed Type: \_\_\_\_\_

Existing Color: \_\_\_\_\_

Proposed Color: \_\_\_\_\_

Existing Material: \_\_\_\_\_

Proposed Material: \_\_\_\_\_

Additional Info Included:  Yes  No

Specs/Photos Included:  Yes  No

Is this item being repaired?  Yes  No

Is this item being replaced?  Yes  No

**I seek tax credit pre-approval for this item.**

**For any proposed door replacement—the spec sheets must show the actual panel and window arrangement of new doors. Photos of existing doors should indicate the location on the house of any door proposed to be replaced.**

**WINDOWS:** Refer to page 38 of the Ellicott City Guidelines and page 26 of the Lawyers Hill Guidelines.

Existing Material: \_\_\_\_\_

Proposed Material: \_\_\_\_\_

Existing Color: \_\_\_\_\_

Proposed Color: \_\_\_\_\_

Existing Sash Arrangement: \_\_\_\_\_

Proposed Sash Arrangement: \_\_\_\_\_

Additional Info Included:  Yes  No

Specs/Photos Included:  Yes  No

Is this item being repaired?  Yes  No

Is this item being replaced?  Yes  No

**I seek tax credit pre-approval for this item.**

**For any proposed window replacement —the spec sheets must show the actual sash arrangement of the new windows. Photos of existing windows should indicate the location on the house of any window proposed to be replaced.**

**WALLS/SIDING:** Refer to pages 25-30 of the Ellicott City Guidelines and pages 21-24 of the Lawyers Hill Guidelines.

Existing Material: \_\_\_\_\_

Proposed Material: \_\_\_\_\_

Existing Color: \_\_\_\_\_

Proposed Color: \_\_\_\_\_

Additional Info Included:  Yes  No

Specs/Photos Included:  Yes  No

Is this item being repaired?  Yes  No

Is this item being replaced?  Yes  No

**I seek tax credit pre-approval for this item.**

**\*Replacing damaged siding with matching wood product.**

## Part 2: General Application for Certificate of Approval Checklist

**TYPE OF ALTERATION:** Please check the appropriate box for the proposed work and fill in required blanks. You may create your own document if it better explains the project, be sure to include details such as materials and colors for all existing/previously existing and proposed features.

**PAINTING:** Refer to page 50 of the Ellicott City Guidelines and page 31 of the Lawyers Hill Guidelines.

Existing Color: \_\_\_\_\_

Proposed Color: \_\_\_\_\_

Paint Chip Included:  Yes  No

Area(s) to be painted: \_\_\_\_\_

Additional Info Included:  Yes  No

\_\_\_\_\_

**I seek tax credit pre-approval for this item.**

**ROOF:** Refer to page 31 of the Ellicott City Guidelines and page 26 of the Lawyers Hill Guidelines.

Existing Material: \_\_\_\_\_

Proposed Material: \_\_\_\_\_

Existing Color: \_\_\_\_\_

Proposed Color: \_\_\_\_\_

Additional Info Included:  Yes  No

Specs/Photos Included:  Yes  No

Is this item being repaired?  Yes  No

Is this item being replaced?  Yes  No

**I seek tax credit pre-approval for this item.**

**SHUTTERS:** Refer to page 42 of the Ellicott City Guidelines and page 28 of the Lawyers Hill Guidelines.

Existing Type: \_\_\_\_\_

Proposed Type: \_\_\_\_\_

Existing Color: \_\_\_\_\_

Proposed Color: \_\_\_\_\_

Existing Material: \_\_\_\_\_

Proposed Material: \_\_\_\_\_

Additional Info Included:  Yes  No

Specs/Photos Included:  Yes  No

Is this item being repaired?  Yes  No

Is this item being replaced?  Yes  No

**I seek tax credit pre-approval for this item.**

**OTHER (such as lighting, railings, other repairs, tree removal, demolition, etc. Please explain in detail):** Refer to applicable Guidelines. For signs please use separate Sign Application. For New Construction use separate New Construction Application. Please attach additional pages as necessary or write up separate document.

Description: Teak exterior furniture to accompany proposed stone patio and fire pit.

\_\_\_\_\_

Specs/Photos Included:  Yes  No

Additional Info Included:  Yes  No

Is this item being repaired?  Yes  No

Is this item being replaced?  Yes  No

**I seek tax credit pre-approval for this item.**

### Part 3: Historic Property Tax Credits

#### Historic Property Tax Credits 20.112 and 20.113 Eligibility Requirements

Please check the appropriate box:

In accordance with Sections 16.606, 20.112 and 20.113 of the Howard County Code, I request the pre-approval of eligible work to qualify for property tax credits for the following preservation and restoration work:

- A structure listed on (or eligible for inclusion in) the Howard County Historic Sites Inventory and is designated by the Commission as historically significant.
- An existing principal structure or historic outbuilding located within a local historic district in Howard County, which is determined by the Commission to be of historic or architectural significance, or to be architecturally compatible with the historic structures in the district .
- A landscape feature located within a local historic district or listed on the Historic Sites Inventory, which is determined by the Commission to be of historic or architectural significance.
- A cemetery, at least 50 years old, not operated as a business, which is listed on the Howard County Cemetery and Gravesites Inventory under Section 16.1303 of the County Code.

Please Note: There is a separate application for final tax credit approval. Copies of cancelled checks, receipts and paid invoices are required for final approval. Invoices should be itemized to separate repairs to the items pre-approved from those that are not eligible for the tax credit.

### Part 4: Authorizing Signature to Submit Application:

I hereby certify by the below signatures(s) that the information supplied herewith is correct and complete and authorizes such periodic on-site inspections by the Department of Planning and Zoning and its agents as may be necessary to review this application and any petitions filed in connection herewith and to enforce the Historic District Guidelines and other applicable laws. This right-of-entry shall continue until all administrative appeals pertaining to the property have been exhausted. I have read and understand the above terms regarding the Historic Property Tax Credit Programs.

#### SIGNATURE(S):

If the Applicant is not the owner of the subject property, the owner's signature authorizing the proposed work is required .

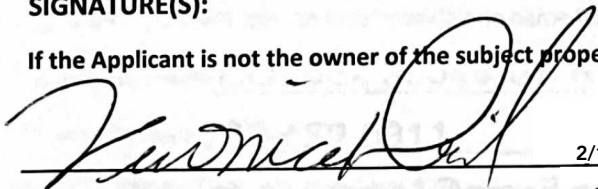
  
\_\_\_\_\_  
Applicant or Authorized Agent

2/18/2020  
\_\_\_\_\_  
Date

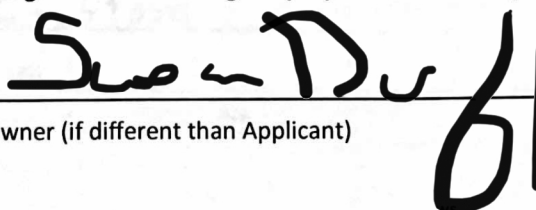
  
\_\_\_\_\_  
Owner (if different than Applicant)

2/18/2020  
\_\_\_\_\_  
Date

**Fire Pit Furniture  
for**

3731 Hamilton St, Ellicott City, MD 21043



Plot Plan for Fire Pit



# PARKING LOT

-  10 BOXWOODS
-  8 SCHIP LAURELS
-  LENTEN ROSES
-  WINTER JASMINE
-  4" METAL-IRON 10' HIGH POSTS FOR HANGING PLANTS AND STRING LIGHTS
-  DARK BROWN MULCH

Proposed position of Fire Pit

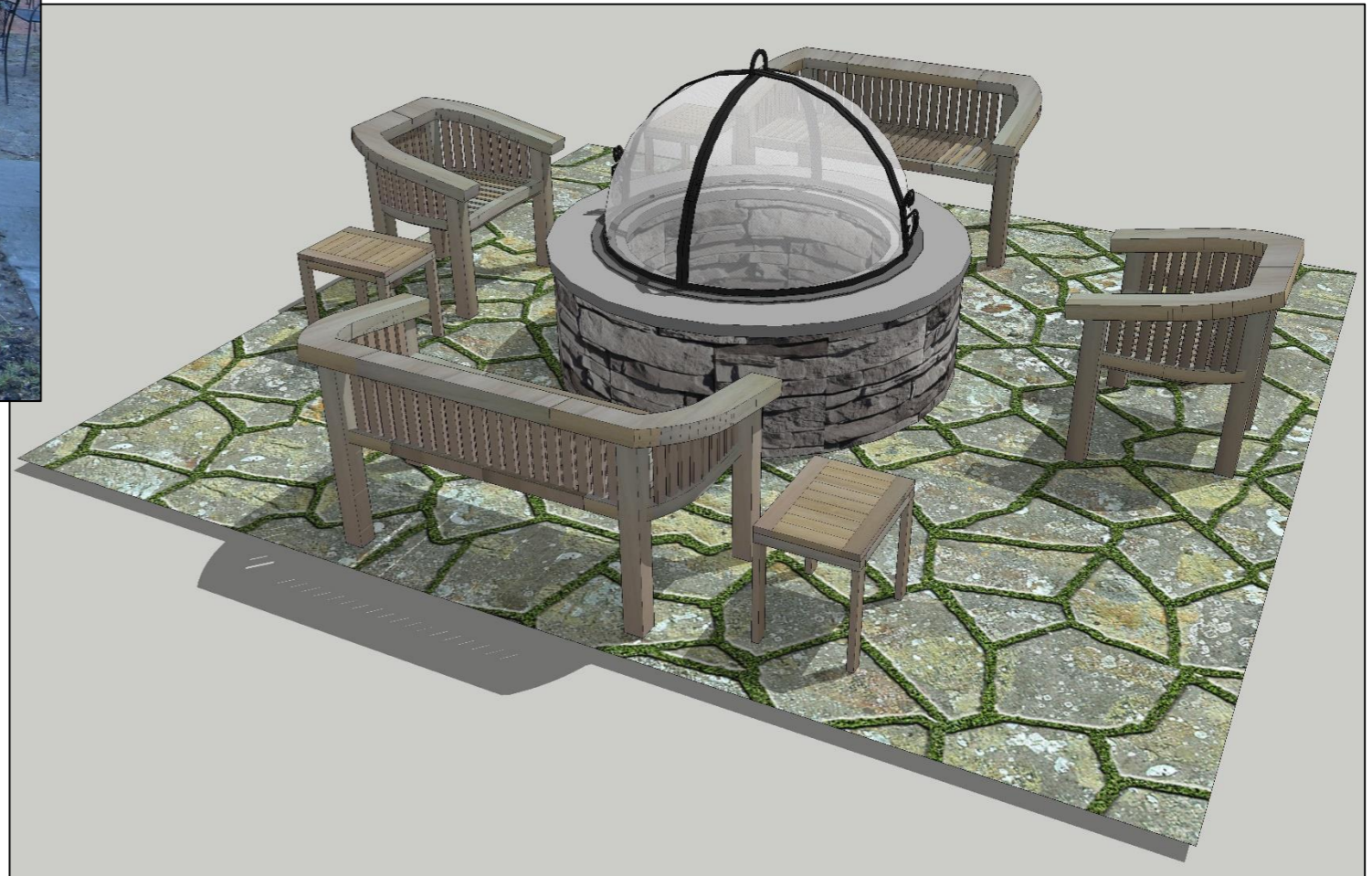

Proposed location of Fire Pit with Furniture



## Teak Exterior Furniture for Fire Pit area

- (2) Benches
- (2) Chairs
- (4) Side Tables

# HOWARD COUNTY HISTORIC PRESERVATION COMMISSION

## GENERAL APPLICATION FOR CERTIFICATE OF APPROVAL AND TAX CREDIT PRE-APPROVAL

**SUBMIT 10 COPIES** of this application package, including all supporting materials required on pages 2-5 of this application to Howard County Department of Planning and Zoning. Applications must be received no later than 5:00 pm 22 days prior to the meeting. Applications can be submitted via mail, but may result in missing the deadline. Applications are not accepted via email or fax.

Address: 3430 Court House Drive, Ellicott City, MD 21043

### Meeting Information

The Historic Preservation Commission (HPC) meets at 7:00 pm generally on the first Thursday of each month at 3430 Court House Dr., Ellicott City, MD. Please contact us regarding emergency applications.

### Questions

Please contact Samantha Holmes, Historic Preservation Planner at 410-313-4428 or [sholmes@howardcountymd.gov](mailto:sholmes@howardcountymd.gov).

### FOR STAFF USE ONLY

#### Application #:

HPC -

MA - **20-18**

#### Meeting Date:

**posted online**

#### Date Received:

**2/19/20**

### PROPERTY INFORMATION

Address of Subject Property: **3731 Hamilton St. Ellicott City, MD., 21043**

Name of Property Owner: **Susan Duff**

Historic District (please check):  Ellicott City Local Historic District  Lawyers Hill Local Historic District

Is this property listed on the Howard County Historic Sites Inventory?  Y  N #HO- \_\_\_\_\_

### APPLICANT INFORMATION

Name of Applicant (please only provide one name for contact purposes): **Veronica Daniel**

Mailing address: **P.O. Box 33044 Granada Hills, CA., 91394**

Phone No. (W) **330-459-0311** (H) \_\_\_\_\_

Email: **veronica.christine1@gmail.com** Contact Preference: **email**

### BELOW FOR STAFF USE ONLY

Tax Account Number: \_\_\_\_\_

Map \_\_\_\_\_ Parcel \_\_\_\_\_

## Part 1: General Application for Certificate of Approval

**ALL APPLICATIONS MUST INCLUDE:** The information required in this checklist must be provided or the application will be incomplete and may be rejected for consideration by the Commission. Please check each box below to confirm you have provided this information.

- Labeled, color photographs of existing property conditions, printed on 8.5x11 paper, no more than two images per page. Do not submit individual 4x6 photographs.
- A detailed description of the proposed work (include below or provide on a separate sheet of paper if more space is needed— do not add proposed work into the Guidelines justification section).
- Product specification sheets/photographs of product that clearly shows materials, colors, and dimensions.
- Plot plan of property, site plans, or elevations (as applicable to proposal; but required for any new construction).
- For major alterations: elevation drawings of proposed structure indicating dimensions, design, height, color, and materials. Product spec sheets are required for all new elements.
- A completed Part 2 of this application (page 3-4). Application may be rejected if not complete. If Part 2 is not suitable for your project, please type up a detailed explanation on a separate piece of paper.
- A completed Part 3 of this application (page 5) if you seek tax credits for any work.
- A completed Part 4 of this application (page 5). If the owner is not the applicant, the owner's signature is also required.
- I have read the Ellicott City or Lawyers Hill Design Guidelines and find my proposal complies with the recommendations in the Guidelines, as indicated below.

**DESCRIPTION OF PROPOSAL:** If more room is required, please provide write up on a separate sheet of paper to best organize proposed work. Continue to Part 2 (page 3-5) to complete required checklists.

To provide a 40"x40"x40" hinged "Hide Screen" in front of the existing exterior AC unit. The proposed hide screen would be constructed from 2"x4"

framing and 1"x6" cedar planks then stained with a weather resistant exterior stain coat.

**DESIGN GUIDELINES:** Consult the Ellicott City or Lawyers Hill Design Guidelines on the Howard County website at <https://www.howardcountymd.gov/Departments/Planning-and-Zoning/Conservation-and-Preservation/Historic> and provide a brief description of how the proposal meets the recommendations of the Guidelines, including the applicable chapter and section. Please type up on a separate sheet of paper if more space is needed.

## Part 2: General Application for Certificate of Approval Checklist

TYPE OF ALTERATION: Please check the appropriate box for the proposed work and fill in required blanks. Specs sheets and photos must be provided or the application may be considered incomplete and rejected for consideration by the Commission.

You may create your own document if it better explains the project, be sure to include details such as materials and colors for all existing/previously existing and proposed features.

**DOORS AND STORMS DOORS:** Refer to page 35 of the Ellicott City Guidelines and pages 26-29 of the Lawyers Hill Guidelines.

Existing Type: \_\_\_\_\_

Proposed Type: \_\_\_\_\_

Existing Color: \_\_\_\_\_

Proposed Color: \_\_\_\_\_

Existing Material: \_\_\_\_\_

Proposed Material: \_\_\_\_\_

Additional Info Included:  Yes  No

Specs/Photos Included:  Yes  No

Is this item being repaired?  Yes  No

Is this item being replaced?  Yes  No

**I seek tax credit pre-approval for this item.**

**For any proposed door replacement—the spec sheets must show the actual panel and window arrangement of new doors. Photos of existing doors should indicate the location on the house of any door proposed to be replaced.**

**WINDOWS:** Refer to page 38 of the Ellicott City Guidelines and page 26 of the Lawyers Hill Guidelines.

Existing Material: \_\_\_\_\_

Proposed Material: \_\_\_\_\_

Existing Color: \_\_\_\_\_

Proposed Color: \_\_\_\_\_

Existing Sash Arrangement: \_\_\_\_\_

Proposed Sash Arrangement: \_\_\_\_\_

Additional Info Included:  Yes  No

Specs/Photos Included:  Yes  No

Is this item being repaired?  Yes  No

Is this item being replaced?  Yes  No

**I seek tax credit pre-approval for this item.**

**For any proposed window replacement —the spec sheets must show the actual sash arrangement of the new windows. Photos of existing windows should indicate the location on the house of any window proposed to be replaced.**

**WALLS/SIDING:** Refer to pages 25-30 of the Ellicott City Guidelines and pages 21-24 of the Lawyers Hill Guidelines.

Existing Material: \_\_\_\_\_

Proposed Material: \_\_\_\_\_

Existing Color: \_\_\_\_\_

Proposed Color: \_\_\_\_\_

Additional Info Included:  Yes  No

Specs/Photos Included:  Yes  No

Is this item being repaired?  Yes  No

Is this item being replaced?  Yes  No

**I seek tax credit pre-approval for this item.**

**\*Replacing damaged siding with matching wood product.**

## Part 2: General Application for Certificate of Approval Checklist

**TYPE OF ALTERATION:** Please check the appropriate box for the proposed work and fill in required blanks. You may create your own document if it better explains the project, be sure to include details such as materials and colors for all existing/previously existing and proposed features.

**PAINTING:** Refer to page 50 of the Ellicott City Guidelines and page 31 of the Lawyers Hill Guidelines.

Existing Color: \_\_\_\_\_

Proposed Color: \_\_\_\_\_

Paint Chip Included:  Yes  No

Area(s) to be painted: \_\_\_\_\_

Additional Info Included:  Yes  No

**I seek tax credit pre-approval for this item.**

**ROOF:** Refer to page 31 of the Ellicott City Guidelines and page 26 of the Lawyers Hill Guidelines.

Existing Material: \_\_\_\_\_

Proposed Material: \_\_\_\_\_

Existing Color: \_\_\_\_\_

Proposed Color: \_\_\_\_\_

Additional Info Included:  Yes  No

Specs/Photos Included:  Yes  No

Is this item being repaired?  Yes  No

Is this item being replaced?  Yes  No

**I seek tax credit pre-approval for this item.**

**SHUTTERS:** Refer to page 42 of the Ellicott City Guidelines and page 28 of the Lawyers Hill Guidelines.

Existing Type: \_\_\_\_\_

Proposed Type: \_\_\_\_\_

Existing Color: \_\_\_\_\_

Proposed Color: \_\_\_\_\_

Existing Material: \_\_\_\_\_

Proposed Material: \_\_\_\_\_

Additional Info Included:  Yes  No

Specs/Photos Included:  Yes  No

Is this item being repaired?  Yes  No

Is this item being replaced?  Yes  No

**I seek tax credit pre-approval for this item.**

**OTHER (such as lighting, railings, other repairs, tree removal, demolition, etc. Please explain in detail):** Refer to applicable Guidelines. For signs please use separate Sign Application. For New Construction use separate New Construction Application. Please attach additional pages as necessary or write up separate document.

Description: To provide a hinged "hide screen" in front of the existing AC unit.

Specs/Photos Included:  Yes  No

Additional Info Included:  Yes  No

Is this item being repaired?  Yes  No

Is this item being replaced?  Yes  No

**I seek tax credit pre-approval for this item.**

### Part 3: Historic Property Tax Credits

#### Historic Property Tax Credits 20.112 and 20.113 Eligibility Requirements

Please check the appropriate box:

In accordance with Sections 16.606, 20.112 and 20.113 of the Howard County Code, I request the pre-approval of eligible work to qualify for property tax credits for the following preservation and restoration work:

- A structure listed on (or eligible for inclusion in) the Howard County Historic Sites Inventory and is designated by the Commission as historically significant.
- An existing principal structure or historic outbuilding located within a local historic district in Howard County, which is determined by the Commission to be of historic or architectural significance, or to be architecturally compatible with the historic structures in the district .
- A landscape feature located within a local historic district or listed on the Historic Sites Inventory, which is determined by the Commission to be of historic or architectural significance.
- A cemetery, at least 50 years old, not operated as a business, which is listed on the Howard County Cemetery and Gravesites Inventory under Section 16.1303 of the County Code.

Please Note: There is a separate application for final tax credit approval. Copies of cancelled checks, receipts and paid invoices are required for final approval. Invoices should be itemized to separate repairs to the items pre-approved from those that are not eligible for the tax credit.

#### Part 4: Authorizing Signature to Submit Application:

I hereby certify by the below signatures(s) that the information supplied herewith is correct and complete and authorizes such periodic on-site inspections by the Department of Planning and Zoning and its agents as may be necessary to review this application and any petitions filed in connection herewith and to enforce the Historic District Guidelines and other applicable laws. This right-of-entry shall continue until all administrative appeals pertaining to the property have been exhausted. I have read and understand the above terms regarding the Historic Property Tax Credit Programs.

#### SIGNATURE(S):

If the Applicant is not the owner of the subject property, the owner's signature authorizing the proposed work is required .

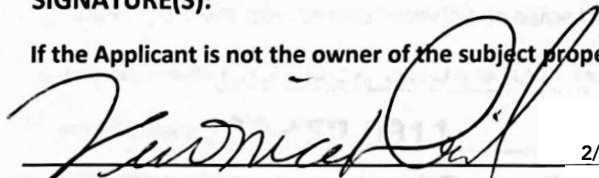
  
\_\_\_\_\_  
Applicant or Authorized Agent                      Date

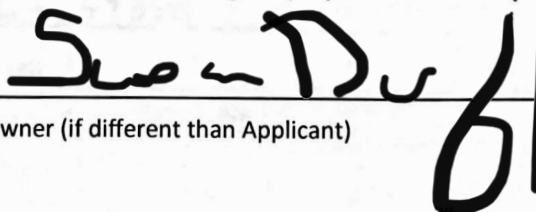
  
\_\_\_\_\_  
Owner (if different than Applicant)                      Date

# Air Conditioner Hide/Screen for

3731 Hamilton St, Ellicott City, MD 21043



Plot Plan for AC Screen



Proposed location of AC Screen



Location of AC Unit

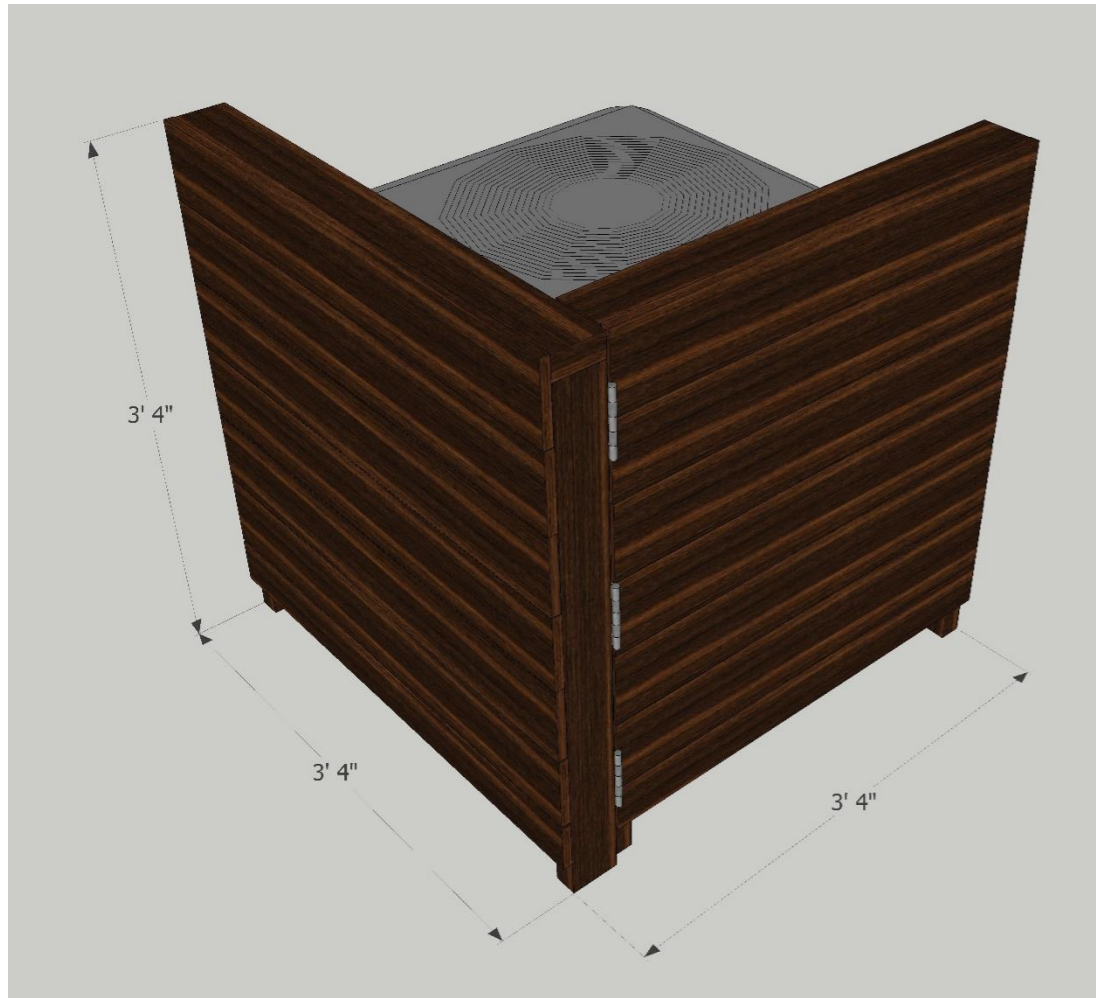

AC Screen Dimensions

**BEHR** >  
 1 gal. #PPF-51 Dark Walnut  
 Solid Color House and Fence  
 Exterior Wood Stain

★★★★★ (111) Write a Review

- Resists UV and water damage
- Self-priming
- Resists moisture, cracking and blistering

**\$25<sup>98</sup>**

Save up to \$100\* on your qualifying purchase.  
 Apply for a Home Depot Consumer Card

Container Size: **1 GA-Gallon**

1 GA-Gallon 5 GA-Gallon

AC Screen Stain Color