

---

**INVITATION FOR BIDS**  
**IFB NO. 2016-60**  
**OAKLAND WATER TANK CLEANING AND COATING**

**OPENING: MARCH 9, 2016 AT 2:00 P.M.**  
**PRE-BID CONFERENCE: FEBRUARY 24, 2016 AT 9:00 A.M.**

**BUYER: Anna Anuszewski, Buyer**  
**PHONE: 410-313-6378 ▪ EMAIL: [aanuszewski@howardcountymd.gov](mailto:aanuszewski@howardcountymd.gov)**

---



---

**HOWARD COUNTY, MARYLAND**

---

**OFFICE OF PURCHASING**

6751 Columbia Gateway Drive, Suite 501, Columbia, MD 21046  
[www.howardcountymd.gov/purchasing](http://www.howardcountymd.gov/purchasing)



*Formal IFBs and IFB Results are available on our website*

## KEY INFORMATION SUMMARY

|   |   |
|---|---|
| <b>IFB No.:</b>                                 | IFB 2016-60   |
| <b>IFB Name:</b>                                | Oakland Water Tank Cleaning and Coating   |
| <b>Issue Date:</b>                              | February 11, 2016   |
| <b>Buyer:</b>                                   | Anna Anuszewski, Buyer<br><a href="mailto:aanuszewski@howardcountymd.gov">aanuszewski@howardcountymd.gov</a><br>410-313-6378  |
| <b>Pre-Bid Date:</b>                            | February 24, 2016 at 9:00 a.m.  |
| <b>Pre-Bid Location</b>                         | Conference Room, Bureau of Utilities<br>8270 Old Montgomery Road<br>Columbia, MD 21045<br>Please register by contacting Karen Aghdassi at<br><a href="mailto:kaghdassi@howardcountymd.gov">kaghdassi@howardcountymd.gov</a> |
| <b>Questions Due and to Whom:</b>               | Questions due no later than 4:00 p.m. on March 2, 2016<br>Submit questions to: Anna Anuszewski at<br><a href="mailto:aanuszewski@howardcountymd.gov">aanuszewski@howardcountymd.gov</a>                                     |
| <b>Bid Due:</b>                                 | March 9, 2016 prior to 2:00 P.M.  |
| <b>Mail/Deliver Bids to the Issuing Office:</b> | Office of Purchasing<br>6751 Columbia Gateway Dr., Ste. 501<br>Columbia, MD 21046<br>410-313-6370   |
| <b>Agreement Term:</b>                          | Per specifications  |
| <b>Bid Deposit/ Performance Bond:</b>           | Yes, both are required. Refer to Section A, paragraph(s) 4 and 5  |
| <b>EBO Subcontracting Participation:</b>        | 10% Refer to Section F, Bid Submittals  |

MINORITY BUSINESS ENTERPRISES are encouraged to respond to this solicitation. For more information, please contact Mr. Mahesh Sabnani, Equal Business Opportunity Coordinator, at 410-313-6370.

### IMPORTANT NOTICE REGARDING ADDENDA

Addenda to solicitations often occur prior to bid opening. It is the potential bidder's responsibility to regularly visit the PlanWell web site ([www.e-arc.com/md/columbia](http://www.e-arc.com/md/columbia)) or the Office of Purchasing web site ([www.howardcountymd.gov/purchasing](http://www.howardcountymd.gov/purchasing)) for addenda to solicitations.

In order to receive notification of addenda, potential bidders must be registered on the Planholders List by registering on PlanWell.

Howard County, Maryland  
Office of Purchasing  
Gateway Building, 5th Floor  
6751 Columbia Gateway Drive  
Columbia, Maryland 21046

INVITATION FOR BID 2016-60  
OAKLAND WATER TANK CLEANING AND COATING

| <u>SECTION</u> | <u>DESCRIPTION</u>   | <u>NUMBER<br/>OF PAGES</u> |
|----------------|--|----------------------------|
|                | <b>KEY INFORMATION SUMMARY</b>                             | <b>1</b>                   |
| <b>A</b>       | <b>INFORMATION FOR CONTRACTORS</b>                         | <b>6</b>                   |
| <b>B</b>       | <b>GENERAL CONDITIONS</b>                                  | <b>1</b>                   |
| <b>C</b>       | <b>SPECIAL PROVISIONS</b>                                  | <b>1</b>                   |
| <b>D</b>       | <b>TECHNICAL SPECIFICATIONS</b>                            | <b>8</b>                   |
| <b>E</b>       | <b>SAMPLE DOCUMENTS TO BE EXECUTED UPON CONTRACT AWARD</b> |                            |
|                | Performance Bond   | 4                          |
|                | Payment Bond   | 3                          |
|                | Contractor Agreement                                       | 2                          |
|                | Attachment to Contractor Agreement                         | 3                          |
| <b>F</b>       | <b>BID SUBMITTALS</b>                                      |                            |
|                | Bid Submittal Form Checklist                               | 1                          |
|                | Total Amount of Bid Form                                   | 1                          |
|                | Addendum Identification and Acknowledgment                 | 1                          |
|                | Schedule of Prices   | 3                          |
|                | Corporation Information Sheet                              | 1                          |
|                | Qualifications Questionnaire                               | 12                         |
|                | Affidavit  | 1                          |
|                | Equal Business Opportunity (EBO) Schedule of Participation | 3                          |
|                | Wage Rate Requirement for Service Contracts                | 2                          |
| <b>G</b>       | <b>APPENDICES</b>  |                            |
|                | Appendix A – Flat Surface Area Square Footage Estimate     | 1                          |
|                | Appendix B – Ariel map                                     | 1                          |
|                | Appendix C – Sizing and Color Diagram                      | 1                          |
|                | Appendix D - Photo   | 1                          |
|                | Appendix E – Drip Edge Diagram                             | 1                          |

**IMPORTANT: ADVISE OFFICE OF PURCHASING IMMEDIATELY IN THE EVENT ANY OF THE ABOVE SECTIONS ARE MISSING.**

# **INFORMATION FOR** **CONTRACTORS**

**INFORMATION FOR CONTRACTORS**

**CONTENTS**

---

| <b><u>PARAGRAPH</u></b> | <b><u>TITLE</u></b>                                      | <b><u>PAGE NO.</u></b> |
|-------------------------|--|------------------------|
| 1.                      | Submission of Bid Documents                              | A-1                    |
| 2.                      | Pre-bid Meeting  | A-2                    |
| 3.                      | Project Manager  | A-2                    |
| 4.                      | Bid Deposit  | A-2                    |
| 5.                      | Performance / Payment Bond                               | A-2                    |
| 6.                      | Bidder's Qualifications                                  | A-3                    |
| 7.                      | Method of Award  | A-4                    |
| 8.                      | Work Schedule  | A-4                    |
| 9.                      | Prohibitions Against Discrimination                      | A-5                    |
| 10.                     | Cooperative Purchasing                                   | A-5                    |
| 11.                     | Protest  | A-5                    |
| 12.                     | Authority  | A-5                    |
| 13.                     | Maryland Registration                                    | A-6                    |
| 14.                     | Background Checks and Investigations (for Services Only) | A-6                    |

**INFORMATION FOR CONTRACTORS**

**1. SUBMISSION OF BID DOCUMENTS**

- 1.1 This Invitation to Bid requires the return of all Bid Submittals, Section “F”. Failure to return the required documents may be cause for rejection of bid.
- 1.2 The required bid documents shall be submitted, in Duplicate (an Original and 1 Copy), to the Howard County Office of Purchasing, Gateway Building, 6751 Columbia Gateway Drive, Suite 501, Columbia, MD 21046 no later than the date and time specified in the Key Information Summary. Unless otherwise specified, all formal bids submitted shall be irrevocable for 60 calendar days following the bid opening date.
- 1.3 Each bid must be submitted in a sealed envelope plainly marked to indicate its contents. The envelope shall be addressed to the Howard County, Maryland, Office of Purchasing at the address noted on the Key Information Summary and shall include the project name, capital project number (contract number if applicable), the bid opening date and the time of bid opening on the envelope. All bids shall be filed prior to the time and at the place specified in the Invitation for Bids, as amended by any applicable addenda. Bids received after the time of opening of bids will be returned to the Bidder unopened.
- 1.4 Proposals made on anything other than the attached documents will not be considered. Changes in phraseology of the proposal, additions, or limiting provisions, will render the proposal nonresponsive and may cause its rejection.
- 1.5 Each bid shall be accompanied by the Affidavit regarding price fixing, gratuities, bribery, and discriminatory employment practices in accordance with Section E.1.c. (3)(b) of the Howard County Purchasing Manual. When the Contractor is a corporation, a duly authorized representative of said corporation shall execute the Affidavit. The Affidavit is provided in the solicitation package.
- 1.6 The Foreign Services Disclosure Form must accompany bids for construction-related services, architectural services, engineering services and energy performance contract services of \$2 million or more. Section 12-111 of the Maryland State Finance and Procurement Article requires bidders to local governments to make certain disclosures regarding plans, at the time the bid is submitted, to perform any services under the contract outside the United States. When applicable, the Foreign Services Disclosure form is provided in the solicitation package.
- 1.7 All bidders must be familiar with the general conditions, terms, and regulations for the bid. In case of conflicts between the contract documents, the order of precedence shall be: (1) Addenda to Invitations for Bids; (2) Information for Contractors; (3) Special Provisions; (4) Plans (Drawings); (5) Technical Specifications; (6) Volume IV Design Manual, Standard Specifications and Details for Construction; (7) SHA Standard “Standard Specifications for Construction and Materials” (January, 2008).
- 1.8 If a discrepancy in or omission from the specifications is found, or if a Contractor is in doubt as to their meaning, or feels that the specifications are discriminatory, the Contractor shall notify the Buyer in writing not later than ten (10) days prior to the

scheduled opening of bids. Exceptions taken do not obligate the County to change the specifications. The Issuing Office will notify all Contractors of any changes, additions or deletions to the specifications by addenda.

- 1.9 The submission of a proposal on this work and service will be considered as a representation that the bidder has carefully investigated (1) all conditions which affect or may, at some future date, affect the performance of the work or services covered by the proposal, (2) the entire area to be serviced as described in the attached specifications and other contract documents and that the bidder is fully informed concerning the conditions to be encountered; and (3) the character, quality and quantity of work to be performed and equipment and materials to be furnished. Also, that the bidder is familiar with all Federal, State, and County laws, all codes and ordinances of the County which in any way affect the prosecution of the work or persons engaged or employed in the work or the materials and equipment used in the work.
- 1.10 Any quantities given under the various items of the proposal are approximate only and subject to increase or decrease, as provided in the contract, without changing the unit prices to be paid for the work.
- 1.11 Bidders must not change any item in the proposal for which the County has stipulated a price. Any such change will cause rejection of the proposal.
- 1.12 The right is hereby reserved to reject any or all proposals, and to waive informalities as the interest of the County may require.

**2. PRE-BID MEETING**

A pre-bid meeting will be held at the date and time specified in the Key Information Summary in the Conference Room, Bureau of Utilities, 8270 Old Montgomery Road, Columbia, MD 21045. Bidder attendance is not required but strongly encouraged.

**3. PROJECT MANAGER**

The Howard County Project Manager for this contract is Mr. John Schaeffer, telephone number: (410) 313-4943.

**4. BID DEPOSIT**

A bid deposit, in the form of a certified check, cashier's check, or bid bond, shall accompany this proposal. The bid deposit shall be 5% of the total bid, made payable to "Director of Finance, Howard County."

**5. PERFORMANCE/PAYMENT BOND**

A performance bond and payment bond for the full amount of the contract price shall be required of the successful bidder within 10 days after award notification. Said bond shall be issued by a surety company subject to approval of Howard County.

**6. BIDDER'S QUALIFICATIONS**

- 6.1 Bidders shall have at least 3 years of experience in the blasting, cleaning, and painting of water storage tanks and must have been actively engaged in this field for a period of not less than three continuous years. Additionally, all Contractors must have experience using the type of coating system specified and must possess necessary certifications. Bidders shall document this experience on the Qualifications Questionnaire (Section F), and provide a detailed list of recently completed projects meeting the specified experience requirements. The experience of owner(s) may be imputed to a newly formed company/contractor provided the owner(s) has/have at least 3 years of demonstrated experience of reliability and meets the criteria set forth herein.
- 6.2 The County reserves the right to inspect the Contractor's equipment and to perform such investigations as may be deemed necessary to insure that competent personnel and management will be utilized in the performance of the Agreement.
- 6.3 In accordance with Howard County Code Sec. 4.117 (a) (4), the quality of performance of previous contracts or services shall be considered in determining the lowest responsive and responsible bidder. Quality of performance may be determined through contracts or services provided to the County or to other entities. Quality of performance to other entities will be determined from reference checks when references are required. The determination of quality performance includes the Contractor's history of reasonable and cooperative behavior and commitment to customer satisfaction and the Contractor's businesslike concern for the interests of the customer. The County reserves the right to reject any bid deemed not responsible or non-responsive.
- 6.4 All Contractors shall have successfully blasted, cleaned, and coated the interior and/or exterior of at least three elevated water tanks.
- 6.5 All Contractors shall have experience with abrasive blasting, high pressure washing, and coatings application.
- 6.6 All Contractors shall have successfully installed and maintained a tank containment system on at least three elevated water tanks.
- 6.7 All Contractors must document their experience on the firm's "Experience and Qualification Sheet", Bid Document "F".
- 6.8 All Contractors must provide an on-site foreman or lead painter who possesses a minimum of three years' experience in the field of water tank coating. This person must remain on-site during the entire work effort.
- 6.8.1 The name of the on-site foreman or lead painter as well as contact information shall be listed with the bid documents.
- 6.8.2 The foreman or lead painter selected shall have successfully blasted, cleaned, and coated the interior and exterior of at least three water tanks of similar type and size. Also, this person shall have experience with abrasive blasting, high pressure washing, and coatings application. This experience shall be document on the

“Experience and Qualification Sheet” for the foreman and/or lead painter, Bid Document “F”.

- 6.8.3 The on-site foreman or lead painter shall have experience with the coating systems specified for use and shall have a thorough knowledge of all aspects of the specific work effort.
- 6.8.4 Contractors shall provide the name of the subcontractor to be used for welding and metal working.
- 6.9 No contract shall be awarded to other than a responsible Contractor meeting all the requirements of these specifications. The County reserves the right to reject all bids if none are deemed fully compliant.
- 6.10 The County reserves the right to inspect the Contractor’s equipment at a convenient site and to perform such investigation as deemed necessary to insure that competent personnel and management will be utilized in the performance of this contract.
- 6.11 The County reserves the right to check all references furnished and, if deemed necessary by the County, visit sites to verify previous work performed, and consider the responses received in determining award of this bid.
- 6.12 Any false information furnished on or with the Contractor’s submittal may be cause for rejection of the bid.

**7. METHOD OF AWARD**

Howard County intends to make award to the lowest responsive responsible bidder meeting all the specifications, having submitted all the required documents, and meeting all necessary experience and reference requirements for the Total Bid.

**8. WORK SCHEDULE**

As part of their bid, the Contractor shall provide a work schedule that includes a start date and a completion date commencing from the date of award Agreement.

- 8.1 Blasting and coating work shall be scheduled between April 1 and November 30 of the scheduled year.
- 8.2 All work shall be completed, as scheduled, using no more than a six-day work week, Monday through Saturday. No work shall be conducted after 7:00 PM. Any deviation from the planned work schedule must be approved in advance by the Project Manager.
- 8.3 The Contractor shall provide all necessary manpower needed to complete the job within the scheduled time frame. The contractor shall provide at least two fully equipped painting crews during coating operations and at least two fully equipped blasting crews during surface preparation.
- 8.4 At no additional cost to the County, the Contractor shall provide additional manpower, equipment, or resources in order to adhere to the proposed work schedule.

- 8.5 A pre-construction meeting will be held at the Bureau of Utilities office approximately two weeks prior to the commencement of work. The Contractor, Inspector, Project Manager and Coatings Manufacturer shall attend this meeting to discuss the planned schedule of work. The Contractor shall provide, at this meeting, a detailed schedule of manpower and equipment to be used in each phase; i.e. installation of containment, erection of staging, blasting, pressure washing, painting, etc. This schedule shall be subject to the approval of the Project Manager.
- 8.6 The County will drain the water tank prior to the scheduled start date; upon completion, the County will notify the contractor that the tank is available for work to begin. The Contractor shall commence work based on the approved work schedule.

**9. PROHIBITIONS AGAINST DISCRIMINATION**

The Contractor and all subcontractors shall not engage in any unlawful employment practice prohibited by law in connection with the work to be done under this contract. The Contractor shall not discriminate against any employee or applicant on the basis of race, creed, color or national origin. The Contractor will take affirmative action to ensure that applicants are employed and that employees are treated during employment without regard to race, creed, color or national origin.

**10. COOPERATIVE PURCHASING**

- 10.1 The County reserves the right to extend all of the terms, conditions, specifications, and unit or other prices of any contract resulting from this bid to any and all public bodies, subdivisions, school districts, community colleges, colleges and universities including non-public schools. This is conditioned upon mutual agreement of all parties pursuant to special requirements which may be appended thereto. The supplier/Contractor agrees to notify the issuing body of those entities that wish to use any contract resulting from this bid and will also provide usage information, which may be requested.
- 10.2 The County assumes no authority, liability or obligation, on behalf of any other public or non-public entity that may use any contract resulting from this bid. All purchases and payment transactions will be made directly between the Contractor and the requesting entity. Any exceptions to this requirement must be specifically noted in the bid response.

**11. PROTEST**

Any protest concerning the award of an Agreement shall be decided by the County. Protests shall be made in writing to the Issuing Office and shall be filed within ten days of issuance of award notification. A protest is considered filed when received by the Issuing Office. The written protest shall include the name and address of the protestor, identification of the procurement, a statement of the specific reason for the protest and supporting exhibits. The Issuing Office will respond to the written protest within ten days. The County's decision is final.

**12. AUTHORITY**

Solicitations are issued pursuant and subject to the provisions of Article VIII, Howard County Charter; Sections 4.100 through 4.123, Howard County Code, 2003; and the rules and regulations as prescribed by the County.

**13. MARYLAND REGISTRATION**

Contractors must be registered to do business in, and must be in good standing in, the State of Maryland. Contractors not registered must obtain registration information from the Maryland Department of Assessments and Taxation website at: [www.dat.state.md.us/](http://www.dat.state.md.us/) or by calling 410-767-1184 or Toll Free 888-246-5941.

**14. BACKGROUND CHECKS AND INVESTIGATIONS**

- 14.1 If a Contractors' employees are on-site in County buildings working without a County escort each employee of the Contractor shall agree to a background check or investigation consisting of national criminal database search covering misdemeanors and felonies and the release of that information to the County in the event that it is required.
- 14.2 The Contractor shall assume the cost to have background checks done for each employee assigned to each facility. The County may bill the Contractor \$100 for each standard background check. Public safety buildings require a higher level of security and an in-depth background checks referred to as "investigations". The County may bill the Contractor \$250 for each in-depth background investigation. This fee, when billed to the Contractor, shall be payable to the County prior to the check or investigation being conducted.
- 14.3 The background checks or investigations shall include all employees, new employees, subcontractors and replacement employees to be done prior to assignment of a building. The checks or investigations will be conducted by the County. The Contractor shall submit the proper forms (provided by the County) to the appropriate County agency, which will be determined if background checks or investigations are necessary.
- 14.4 The Contractor shall not assign any individual convicted of the following offenses which shall include, but are not limited to: Abduction, Homicide, Rape, Aggravated Assault, Sex Offender, Assault with Intent to Murder, or Assault with Intent to Rob.
- 14.5 The Contractor shall not assign any individual convicted, or having incomplete probation for the following offenses which shall include, but are not limited to: Burglary, Breaking and Entering, Carrying or Wearing a Weapon, Destruction of Property, Possession of a Controlled Dangerous Substance with Intent to Distribute, Explosives, Kidnapping, Theft/Larceny, Maiming, Manslaughter, Sexual Assault, Hate Crimes, Robbery, and Distribution of a Controlled Substance.
- 14.6 The Contractor reserves the right to seek exception to the above guidelines governing acceptability for assignment to the facility by providing documented specifics pertaining to convictions of the employee in question. The County will, at its sole discretion, accept or reject the requested exception.

# **GENERAL CONDITIONS**

**GENERAL CONDITIONS**

The Howard County Design Manual, Volume IV, Standard Specifications and Details for Construction, approved and adopted on May 7, 2007 and all subsequent amendments are hereby made a part of this contract. Where reference is made herein or on the Contract Drawings to the Standard Specifications, or Details, it shall be interpreted to refer to the above Howard County Specifications.

Where reference is made to the General Conditions, it shall refer to the General Conditions contained in the above referenced Howard County Design Manual, Volume IV, Standard Specifications and Details for Construction.

All work performed and all materials furnished shall be in conformity with the contract requirements. All work and materials which do not conform to the requirements set forth in this contract will be considered unacceptable unless otherwise determined acceptable by the Project Manager.

# **SPECIAL PROVISIONS**

**This Page Intentionally Left Blank**

# **TECHNICAL** **SPECIFICATIONS**

**1. SCOPE**

Howard County, Maryland, (the "County"), seeks a Contractor (the "Contractor"), to furnish all labor, materials, equipment, and supervision required to clean and recoat the exterior and interior of the Oakland Water Tank; which may include some repair work.

**2. TECHNICAL SPECIFICATIONS**

OAKLAND TANK - The work proposed at the Oakland Water Tank shall include:

- 2.1 Install and maintain a tank containment system to be used during abrasive blasting and painting.
- 2.2 Abrasive blast, clean, prime and apply coating system to all exterior tank surfaces.
- 2.3 Abrasive blast, clean, prime and apply coating system to all wet interior tank surfaces including the inside of the wet riser.
- 2.4 Abrasive blast, clean, prime and apply coating system to the outside of the wet riser pipe, landings, ladder, railings, bottom of bowl, access tube.
- 2.5 Clean and pressure wash the inside wall of the dry riser; spot repair and paint as needed.
- 2.6 Protect all electrical conduit, electrical boxes, electrical fixtures and lighting during blasting and coating.
- 2.7 Complete site restoration.
- 2.8 The Contractor shall be responsible for any and all damages incurred due to their work and operations. The Contractor shall exercise care to avoid damage to the tank and surrounding property.
- 2.9 Fabricate and install drip ring to the perimeter of the tank.

**3. EQUIPMENT**

- 3.1 All equipment shall be in good, safe operating condition and of sufficient capacity to provide satisfactory results for cleaning and painting.
- 3.2 Equipment for high-pressure washing shall be capable of producing water at 4,000 psi. The spray angle shall be no greater than 15 degrees. An on-site fire hydrant is available for use by the Contractor.
- 3.3 Paint shall be applied to the tank exterior by a good quality brush or roller as recommended in the paint manufacturer's specifications.
- 3.4 Scaffolding and rigging shall be installed in a safe and secure manner.

**4. RIGGING ANCHORAGE**

No holes shall be made in any section of the tank to secure rigging. Equipment may only be fastened to the tank using existing rigging holes, clip angles, or painter's rings.

**5. TANK CONTAINMENT SYSTEM**

- 5.1 A complete tank containment system shall be provided during exterior cleaning, blasting and coating operations, which will cover sides and top of tank.
- 5.2 The Contractor shall install, operate, and maintain a tank containment system designed to contain all water spray, blasting debris, and airborne paint within the confines of the tank site. The system shall consist of mesh material, outriggers, cables, pulleys, wench system, and anchors.
- 5.3 The containment system shall completely enclose the tank (sides and top) and must be capable of capturing most all airborne debris generated at all times during cleaning and coating operations. The containment shall be open mesh material with opacity required to contain water, paint and blasting debris.
- 5.4 The system shall be capable of being raised and lowered on a daily basis with the ability to be lowered quickly in the event of an impending storm.
- 5.5 The containment shall be installed such that minimal loads are transmitted to the tank structure.
- 5.6 No part of the containment system shall be used to support rigging equipment, safety lines, or other devices used by painters, inspectors, or other personnel.
- 5.7 The entire system shall be completely removed at the end of the project.
- 5.8 The Contractor shall submit, with their bid, a complete description of the containment system including drawings and manufacturer's literature. An acceptable system shall be designed and supplied by Eagle Industries, Inc. of New Orleans, Louisiana, or an approved equal. Failure to supply adequate information on the proposed containment system shall be considered cause for rejection of bid.
- 5.9 Containment systems shall be inspected and approved by the Project Manager or his designee prior to their installation on the tank.

**6. COATINGWORK SURFACES**

- 6.1 The Oakland tank surface includes: tank bowl, hatches, vent, center column, riser pipes, brackets, ladder and any previously painted surface surrounding or attached to the tank. Not including the inside wall of the dry riser.
- 6.2 The Oakland Water Tank was constructed in 1984 and currently has an epoxy coating system which was applied in 1994.

**7. COATING SURFACE PREPARATION**

Prior to application of primer, all surfaces shall be prepared to receive specified coating system in compliance with manufacturer's recommendations, specifications of Steel Structures Painting Council, and as indicated in Schedule below.

- 7.1 As required, all surfaces shall be abrasively cleaned for removal of old paint, grease, scale, rust, oil, dirt, mold, mildew, and other foreign matter, immediately prior to priming. Surfaces to be

coated shall be clean, dry, and free from dust and foreign matter, which will adversely affect adhesion or appearance.

- 7.2 Any surface blasted must be primer coated the same day.
- 7.3 Surface preparation for dry exterior surfaces shall consist of abrasive blasting in accordance with SSPC-SP-6 specifications (Commercial Blast Cleaning).
- 7.4 Surface preparation for wet interior surfaces including the shall consist of abrasive blasting in accordance with SSPC-SP-10 specifications (Near-White Blast Cleaning).
- 7.5 Surface preparation for dry interior surfaces shall consist of abrasive blasting in accordance with SSPC-SP-6 specifications (Commercial Blast Cleaning)..
- 7.6 The Contractor shall take necessary precautions to avoid damage to existing wiring, cables, electrical fixtures, light fixtures, etc. while executing this work.
- 7.7 Surface preparation shall conformance with local, state, and federal OSHA and EPA guidelines. Waste generation and removal should be in conformance with all OSHA and EPA guidelines.
- 7.8 The Contractor shall take all necessary precautions to prevent damage to surrounding property and equipment.
- 7.9 Adequate dust collection and control shall be provided during blasting operations. The Contractor shall be responsible for any and all damages incurred due to his work and operations. The Contractor shall exercise care to avoid damage to the tank and surrounding property.

**8. COATING APPLICATION**

- 8.1 All coating work shall be done in accordance with the paint manufacturer's recommendations, specifications, and as directed by the County's Project Manager.
- 8.2 The Contractor shall take necessary precautions to avoid damage to existing wiring, cables, electrical fixtures, light fixtures, etc. while executing this work.
- 8.3 The surface area blasted in one day shall be limited to the area that can be prime- coated within that same day.
- 8.4 A brushed, primer strip-coat shall be applied to all welds and gaps between the tank plates, stiffeners, man-ways, roof vent, and any angle or irregular surface.
- 8.5 The Contractor shall exercise care when cleaning and painting to avoid wind borne paint, roller spray, and material from falling on non-County owned property. The Contractor shall be responsible for any and all damages incurred due to his work and operations. The Contractor shall exercise care to avoid damage to the tank and tank property, especially during placement and movement of rigging equipment.
- 8.6 The color scheme shall be two-tone as specified in Appendix C and Appendix D.

**9. COATING SYSTEMS**

- 9.1 All bids shall be based on the coating system specified below.
- 9.2 Exterior Coating System - The coating system for the tank exterior shall be a system designed and manufactured by Tnemec Company of Kansas City, Missouri. The primer, intermediate, and final coats shall be as specified in this section.
- 9.2.1 Strip Coat (Primer) - Tnemec, Series (94H2O Hydro-Zinc). Apply by brush to all tank welds, seams, joints, angles, edges and gaps prepared according to SSPC-SP-6 specifications (Commercial Blast Cleaning).
- 9.2.2 First Coat (Primer) - Tnemec, Series (94H2O Hydro-Zinc). Apply by roller to all exposed surfaces prepared according to SSPC-SP-6 specifications (Commercial Blast Cleaning). All surfaces blasted shall be prime coated the same day. The dry film thickness of the primer shall be 3.0 mils.
- 9.2.3 Second (Intermediate) Coat - Tnemec, Series 750 UVX (Polyfunctional Urethane) Applied by roller to a dry film thickness of 4.0 mils. Colors – Top of Bowl, Legs and Center Column: Bayou Blue(43BL) / Bottom of Bowl and Dry Riser: Windward Island (48BL)
- 9.2.4 Third (Final) Coat - Tnemec, Series V700 Hydroflon (Fluoropolymer Polyurethane) applied by brush or roller to a dry film thickness of 2.5 mils. The exterior color scheme is specified in the attached sketch. Top of Bowl, Legs and Center Column: Diving Board Blue (44BL) / Bottom of Bowl and Dry Riser: Reflection Pool (49BL)
- 9.2.5 The total dry film thickness shall be 9.5 mils.
- 9.3 Interior Wet Coating System - The coating system for the wet interior including the inside of the tank bowl shall be an epoxy system designed for use on steel water tanks and shall be NSF approved for potable water contact. The paint system shall be manufactured by Tnemec Company of Kansas City, Missouri. The primer and final coat shall be as specified in this section.
- 9.3.1 Strip Coat, Primer - Tnemec Series 94-H2O Hydro-Zinc (Aromatic Urethane, Zinc-Rich, one component primer). Apply by brush to all tank welds, seams, joints, angles, edges and gaps prepared according to SSPC-SP10 (Near-White Blast). The dry film thickness of the strip coat shall be 3.0 mils. Color - greenish-gray.
- 9.3.2 First Coat, Primer - Tnemec, 94-H2O Hydro-Zinc (Aromatic Urethane, Zinc-Rich, one component primer). Applied by brush, roller, or spray to all exposed surfaces prepared according to SSPC-SP10 (Near-White Blast). All surfaces blasted shall be prime coated the same day. The dry film thickness of the primer shall be 3.0 mils. Color - greenish-gray.
- 9.3.3 Top Coat - Tnemec, Series 22, Epoxoline (Modified Polyamine Epoxy), 100 percent solids, applied by spray (plural component application) to a dryfilm thickness of 27 mils. Color - 1218 Light Blue
- 9.3.4 The total dry film thickness shall be 30 mils.

- 9.4 Interior Dry Coating System (not including the inside wall of the dry riser) - The coating system for the dry interior shall be an epoxy system designed for use on steel water tanks. The paint system shall be manufactured by Tnemec Company of Kansas City, Missouri. The primer, intermediate, and final coats shall be as specified in this section.
- 9.4.1 First Coat, Primer - Tnemec, 94-H2O Hydro-Zinc (Aromatic Urethane, Zinc-Rich, one component primer). Applied by brush, roller, or spray to all exposed surfaces prepared according to SSPC-SP-6 specifications (Commercial Blast Cleaning). All surfaces blasted shall be prime coated the same day. The dry film thickness of the primer shall be 3.0 mils. Color - greenish-gray.
- 9.4.2 Second (Intermediate) Coat - Tnemec, Series N140, Pota-Pox Plus (Polyamidoamine Epoxy) applied by brush, roller, or spray to a dryfilm thickness of 6.0 mils. Color - 1255 Beige
- 9.4.3 Third (Final) Coat - Tnemec, Series N140, Pota-Pox Plus (Polyamidoamine Epoxy) applied by brush, roller, or spray to a dryfilm thickness of 6.0 mils. Color – 15BL Tank White
- 9.4.4 The total dry film thickness shall be 15.0 mils.

**10. REFUSE REMOVAL/SITE RESTORATION**

- 10.1 All temporary structures, paint cans, and debris caused by the Contractor shall be immediately removed from the site upon completion of his work.
- 10.2 Upon completion of the Contractor's work and prior to final acceptance and final payment, the Contractor shall restore the site to its original condition. This will include removal of any construction debris, filling/regrading of any tire marks left on the tank property, and reseeded and straw placement for any grass areas damaged during the course of the project.
- 10.3 During the execution of the work, the Contractor shall be responsible for maintaining a clean work and storage area.

**11. INCIDENT RESPONSE PLAN FOR DAMAGES**

An Incident Response Plan shall contain procedures for responding to any damage complaint resulting from the cleaning and coating operations. The plan shall include information on your company, office contact and local on-site contact; procedures for inspecting surrounding properties, monitoring of wind conditions and controlling paint application to reduce fugitive paint and grit; procedure to deal with complaints; and any other information you believe would be useful. Also, provide company information for any subcontractor to be used for repairing fugitive paint or grit damage.

**12. STANDARDS**

- 12.1 All work shall be done in accordance with requirements hereinafter specified and with applicable requirements and specifications of the Steel Structures Painting Council (SSPC) and the AmericanWaterWorks Association (AWWA).
- 12.2 Reference Specifications (including but not limited to):

- 12.2.1 AWWAD100-84Welded Steel Tanks for Water Storage
  - 12.2.2 AWWAD102-78 Painting Steel Water Storage Tanks
  - 12.2.3 SSPC-SP2, 3, 10 & 11 Steel Structures Painting Manual, Systems and Specifications for Surface Preparation
  - 12.2.4 SSPC-VIS1-67T Pictorial Surface Preparation Standards Visual Standard for Degree of Rusting
  - 12.2.5 SSPC-PA 1-64 Shop, Field , and Maintenance Painting
  - 12.2.6 SSPC-PA 2-73T Measurement of Dry Paint Thickness
- 12.3 In case of conflict between this specification and the standard AWWA and SSPC specifications referred to above, this specification shall govern.

**13. HEALTH AND SAFETY REQUIREMENTS**

The Contractor shall comply with the requirements and standards of the Occupational Safety and Health Act (OSHA) and all other state and local laws, ordinances, and codes governing all work to be provided under the contract documents. In particular, strict adherence to the following standards is required:

- 13.1 Occupational Safety and Health Standard: General Industry, 29CFR1910
- 13.2 Occupational Safety and Health Standard: Construction Industry Standards 29 CFR 1926
- 13.3 Occupational Safety and Health Standard: Construction Industry Standards 29 CFR 1926.62 Lead

**14. MATERIALS DATA**

- 14.1 All bids shall be based on materials specified herein. Any request for material substitution shall be identified in a separate attachment; listing benefits and cost savings. The total bid, however, shall not include the additional cost nor the savings of a material substitution. Once the contract is awarded the County will not accept material substitution request.
- 14.2 Each Contractor shall submit the manufacturer's technical data sheet for each type of coating specified. The data sheets shall include coating name, coating description, recommended number of coats, theoretical coverage, climatic conditions for use, drying times, required surface preparation, etc. Two complete sets of descriptive literature shall be furnished with the bid.
- 14.3 All coating material used for this contract shall be new and specifically purchased for this job. All coating material shall be delivered to the site in factory sealed containers showing the manufacturer's name, contents, and batch number. Leftover coating material from previous jobs will not be allowed. Documentation of purchase orders and bills of lading shall be required and shall be submitted to the project manager before painting begins.
- 14.4 Coatings may be thinned only as recommended by the manufacturer; the type and amount of thinner must be listed on the product data sheet. Thinning shall not affect the coating thickness as specified; additional coats may be required for adequate film thickness.

- 14.5 All coating material shall be stored in a secure location and protected from freezing and excessive heat. Storage temperatures shall be held within a range as recommended by the manufacturer.
- 14.6 A coating accelerator may be used as necessary based on weather conditions. Approval and recommendations for its use must be obtained from the paint manufacturer and Project Manager.

**15. WARRANTY**

- 15.1 The Contractor warrants the cleaning and coating services furnished to be of the highest quality, complying with the specifications and free from all defects whatsoever in workmanship and materials, for a period of one year from the date of delivery. Replacements and repairs under this warranty are to be made by the Contractor at no cost and to the satisfaction of the County.
- 15.2 The material supplied by the Contractor shall carry the manufacturer's standard new material warranty.
- 15.3 The Contractor shall guarantee the surface preparation and painting system furnished under this contract for a period of one year after the work is completed and a written final acceptance by the County.
- 15.4 The Contractor agrees to guarantee the work performed against all defects in materials and workmanship within the guarantee period. The Contractor shall, at no cost to the County, replace/repair any coating found to be failing (i.e. peeling, bubbling, blistering, cracking, or corroding). The Contractor shall make repairs at all points where failures are observed by removing the deteriorated coatings, cleaning the surface, and recoating with the same paint system. This guarantee shall apply to all recoated areas.
- 15.5 Prior to the expiration of the one year guarantee period, it is agreed that a representative of the County, a representative of the Contractor, and a representative of the paint manufacturer shall make a complete inspection of the tank to identify any areas of coating failure. If any are found, the Contractor shall make corrections at no cost to the County.
- 15.6 If in the event the Contractor fails to re-execute, correct, or repair any work performed under this contract which may be found to be defective, the County may make the necessary repairs and bill the associated costs against the performance bond.

**16. INSPECTION**

- 16.1 All work proposed under this contract shall be subject to inspection by a representative of the County. Inspection service may be full or part time. The presence or absence of an inspector shall not relieve the Contractor of any obligations under this contract.
- 16.2 The Project Manager shall have sole and final authorization to accept or reject the Contractor's work. It will be the contractor's responsibility to repair and bring all areas to within acceptable standards; this includes not only system thickness, but also coating aesthetics. The Contractor shall not continue work in a new area until each area has been inspected and approved. All corrective work must be done at the Contractor's expense.
- 16.3 The Contractor shall maintain adequate rigging facilities for use by the inspector, which may include: scaffolding, boatswain chairs, spider chairs, or other rigging equipment. If removed prior to inspection, the rigging equipment shall be replaced at the Contractors expense and shall remain

in place until the required inspection work is complete. All rigging equipment shall be equipped with safety lines as required by the applicable provisions of OSHA.

- 16.4 Inspection work may include observations and measurements of surface profile, surface preparation, wet film thickness, dry film thickness, surface temperature, testing, and other measurements as required for a thorough inspection of the work effort.
- 16.5 The Contractor shall use alternating colors to allow for better visual inspection of the coating system.
- 16.6 The Contractor shall be familiar with coating specifications, limitations, restrictions, and recommendations for the product. Any deviation from the manufacture's product data sheet shall be reported to the Project Manager. The Contractor shall have on-staff a NACE trained inspector, who shall be responsible for insuring consistency in surface preparation and coating application.

**SAMPLE**  
**DOCUMENTS TO BE**  
**EXECUTED UPON**  
**CONTRACT AWARD**



**HOWARD COUNTY, MARYLAND**  
**PERFORMANCE BOND**

|           |                               |
|-----------|-------------------------------|
| Principal | Business Address of Principal |
| Surety    | Obligee                       |

HOWARD COUNTY, MARYLAND

a corporation of the State of \_\_\_\_\_  
and authorized to do business in the State of  
Maryland

Penal Sum of Bond (express in words and figures) \_\_\_\_\_

Date Bond Executed \_\_\_\_\_

\_\_\_\_\_

\_\_\_\_\_

\_\_\_\_\_

\_\_\_\_\_

\_\_\_\_\_

\_\_\_\_\_

\_\_\_\_\_

\_\_\_\_\_

Contract Number: \_\_\_\_\_

KNOW ALL MEN BE THESE PRESENTS, That we, the Principal named above and Surety named above, are held and firmly bound unto the Obligee named above in the Penal Sum of this Performance Bond stated above, for the payment of which Penal Sum we bind ourselves, our heirs, executors, administrators, personal representatives, successors, and assigns, jointly and severally, firmly by these presents. However, where a surety is composed of corporations acting as co-sureties, we, the co-sureties, bind ourselves, our successors and assigns, in such Penal Sum jointly and severally as well as severally only for the purpose of allowing a joint action or actions against any or all of us, and for all other purposes each co-surety binds itself, jointly and severally with the Principal, for the payment of such sum as appears above its name below, but if no limit of liabilities is indicated, the limit of such liability shall be the full amount of the Penal Sum.

WHEREAS, Principal has entered into or will enter into a contract with Howard County, Maryland, which Contract is described and dated as shown above. The contract and all items incorporated into the Contract, together with any and all changes, extensions of time, alterations, modifications, or additions to the Contract or to the work to be performed thereunder or to the Plans, Specifications, General Provisions, Special Provisions, or any of them, or to any other items incorporated into the Contract shall hereinafter be referred to as the "Contract," which is specifically incorporated herein be reference as if fully set forth herein, including but not limited to the Choice of Law and Forum provisions of the Contract.

WHEREAS, it is one of the conditions precedent to the final award of the Contract that these presents be executed and delivered to the County.

NOW, THEREFORE, this Performance Bond shall remain in full force and effect unless and until the following terms and conditions are met:

1. The Principal shall well and truly perform the Contract, including all warranty or guarantee obligations, and shall discharge any and all liability for latent defects, for which the Surety shall also be liable;
2. The Principal and Surety shall comply with the terms and conditions of this Performance Bond;
3. If the Obligees notifies both the Contractor and the Surety at their addresses described in this Bond that the Obligees is considering declaring the Contractor in default of the Contractor's obligations under the Contract, then, the Surety, at the Obligees's request, shall arrange a conference with the Principal and the Obligees to discuss methods of performing the Contract. If the Obligees, Principal and the Surety agree, the Principal shall be allowed a reasonable time, as determined by the rights to declare the Principal in default under the contract and terminate the Principal's right to proceed or to avail itself of any other right or remedy under the Contract;
4. If the Obligees declares the Contractor in default and terminates the Principal's right to proceed prior to final acceptance, then the Surety shall:
  - a. Undertake to perform and complete the Contract itself through its agents or through independent contractors; or
  - b. Obtain bids or negotiated proposals from qualified contractors acceptable to the Obligees for a contract for performance and completion of the Contract, arrange for a contract to be prepared for execution by the Obligees with a contractor selected with the Obligees's concurrence and acceptable to the Obligees to be secured with performance and payment bonds executed by a qualified Surety in a form acceptable to the Obligees, and pay to the Obligees the cost of completion of the contract in excess of the Balance of the Contract price; or
  - c. If the cost to complete the Contract is in excess of the Balance of the Contract price plus the Penal Sum of the Performance Bond, then either obtain bids or negotiated proposals from qualified contractors acceptable to the Obligees for a contract for performance and completion of the contract, arrange for a contract to be prepared for execution by the Obligees with the contractor selected with the Obligees's concurrence and acceptable to the Obligees, to be secured with performance and payment bonds executed by a qualified Surety in a form acceptable to the Obligees and pay to the Obligees the excess cost of completion up to Penal Sum of the Bond as the excess costs are incurred by the Obligees; or pay to the Obligees the Penal Sum of the Bond within thirty (30) days of the date when the Surety determines the cost to complete the Contract is in excess of the sum of the Penal Sum of the bond and the Balance of the Contract price.
5. If the Surety complies with the obligations contained in paragraph 4 of this Bond, then, the Surety's liability shall be limited to the Penal sum of its bond.

6. If the Surety contests the propriety of the default and termination of the Principal's right to proceed, the Surety shall, nevertheless, comply with the obligations contained in paragraph 4 of this Bond but, in that event, the Surety shall be entitled to exercise all of the Principal's remedies under the Contract, including but not limited to asserting any and all claims which the Principal may have.
7. The balance of the contract Price shall be the total amount payable by the Oblige to the Principal under the Contract after adjustments for any approved change orders, including allowance to the Principal of any amounts received or to be received by the Oblige in settlement of insurance or other claims for damage to which the Contractor is entitled, reduced by all payments properly made to and on behalf of the Principal under the Contract and less any deductions made by the Oblige under the Contract for any damages for which the Principal may be liable to the Oblige under the Contract.
8. If, after notice of default under the contract and termination of the Principal's right to proceed, the Surety does not comply with the obligations contained in paragraph 4 of this Bond, then the Oblige, within fifteen (15) days after notice to the Surety, may have the remaining Contract work completed and the Surety shall be liable for all completion costs and other costs and damages that the Oblige may incur as a result of the Surety's failure to comply with the terms of this Bond.

The Surety hereby stipulates and agrees that no change, extension of time, alteration or addition to the terms of the contract or to the work to be performed thereunder or the Specifications accompanying the same shall in any way affect its obligations under the Bond and it does hereby waive notice of any such change, extension of time, alteration or addition to the terms of the Contract or to the work or to the Specifications. Any increase in the contract amount shall automatically result in a corresponding increase in the penal amount of the Bond, without notice to or consent from the Surety, such notice and consent being hereby waived. Decreases in the contract amount shall not, however, reduce the penal amount of the Bond unless specifically provided for in said change order.

The Performance Bond shall be governed by and construed in accordance with laws of the State of Maryland exclusive of its choice of law rules and any reference herein to the Principal or Surety in the singular shall include all entities in the plural who or which are signatories under the Principal or Surety heading below.

IN WITNESS WHEREOF, Principal and Surety have set their hands and seals to the Performance Bond. It is specifically understood and agreed that this Bond shall be a sealed instrument for all purposes. If any individual is a signatory under the Principal heading below, then each such individual has signed below on his or her own behalf, has set forth below the name of the firm, if any, in whose name he or she is doing business, and has set forth below his or her title as sole proprietor. If any partnership or joint venture is a signatory under the Principal heading below, then all members of each such partnership or joint venture have signed below, each member has set forth below his or her title as a general partner, limited partner, or member of joint venture, whichever is applicable. If any corporation is a signatory under the Principal of Surety name to be set forth below, a duly authorized representative of the corporation to affix below the corporation's seal and to attach hereto a notarized corporate resolution or power of attorney authorizing such action, and each such duly authorized representative to sign below and to set forth below his or her title as a representative of the corporation. If any individual acts as a witness to any signature below, then each such individual has signed below and has set forth below his or her title as a witness. All of the above has been done as of the date of the Bond shown above.

---

In Presence of: Individual Principal  
Witness  
..... as to .....(SEAL)

---

Presence of: Co-Partnership Principal  
Witness  
.....(SEAL)  
(Name of Co-Partnership)  
..... as to By:.....(SEAL)  
..... as to .....(SEAL)  
..... as to .....(SEAL)

---

Corporate Principal  
.....  
Attest: (Name of Corporation)  
.....  
Corporate Secretary By:..... AFFIX  
President CORPORATE  
SEAL

---

.....  
(Surety)  
Attest: (SEAL) By:..... AFFIX  
CORPORATE  
SEAL  
Signature Title:.....  
Bonding Agent's Name:.....  
(Business Address of Surety)  
Agent's Address:.....



**HOWAR COUNTY, MARYLAND**  
**PAYMENT BOND**

\_\_\_\_\_  
Principal Business Address of Principal

\_\_\_\_\_  
Surety Obligee

HOWARD COUNTY, MARYLAND

a corporation of the State of \_\_\_\_\_  
and authorized to do business in the State of  
Maryland

\_\_\_\_\_  
Penal Sum of Bond (express in words and figures)

\_\_\_\_\_  
Date Bond Executed

Description of Contract

\_\_\_\_\_  
\_\_\_\_\_  
\_\_\_\_\_  
\_\_\_\_\_  
\_\_\_\_\_  
\_\_\_\_\_  
\_\_\_\_\_  
\_\_\_\_\_

Contract Number:

\_\_\_\_\_

KNOW ALL MEN BY THESE PRESENTS, That we, the Principal named above and Surety named above, being authorized to do business in Maryland, and having business addresses as shown above, are held and firmly bound unto the Obligee named above, for the use and benefit of Claimants as hereinafter defined, in the Penal Sum of this Payment Bond stated above, for the payment of which Penal Sum we bind ourselves, out heirs, executors, administrators, personal representatives, successors, and assigns, jointly and severally, firmly by these presents. However, where a surety is composed of corporations acting as co-sureties, we, the co-sureties, bind ourselves, out successors and assigns, in such Penal Sum jointly and severally as well as severally only for the purpose of allowing a joint action or actions against any or all of us, and for all other purposes each co-surety binds itself, jointly and severally with the Principal, for the payment of such sum as appears above its name below, but if no limit is indicated, the limit of such liability shall be the full amount of the Penal Sum.

WHEREAS, Principal has entered into or will enter into a Contract with Howard County, Maryland, which Contract is described and dated as shown above, and incorporated herein be reference. The contract and all items incorporated into the modifications, or additions to the contract or to the work to be performed thereunder or to the Plans, Specifications, and Special Provisions, or any of them, or to any other items incorporated into the Contract shall hereinafter be referred to as the "Contract."

WHEREAS, it is one of the conditions precedent to the final award of the Contract that these presents be executed and delivered to the Obligee.

NOW, THEREFORE, the condition of this obligation is such that if the Principal shall promptly make payment to all Claimants as hereinafter defined, for all sums justly due, labor and materials furnished, supplied, and reasonably required for use in the performance of the Contract, then this obligation shall be null and void; otherwise it shall remain in full force and effect, subject to the following conditions:

1. A claimant is defined to be any and all of those persons supplying labor and materials in the prosecution of the work provided for in the Contract entitled to the protection provided by Sec. 17-101, et seq., State Finance and Procurement Article of the Annotated Code of Maryland (“Maryland Little Miller Act”).
2. The above named Principal and Surety hereby jointly and severally agree with the Obligee that every Claimant as herein defined, who has not been paid in full may, pursuant to and when in compliance with the provisions of the Maryland Little Miller Act, sue on this Bond for the use of such Claimant, prosecute the suit to final judgment for such sum or sums as may be justly due Claimant and have execution thereon. The Obligee shall not be liable for the payment of any costs or expenses of any such suit.

The Surety hereby stipulates and agrees that no change, extension of time, alteration or addition to the terms of the Contract or to the work to be performed thereunder or the Specifications accompanying the same shall in any way affect its obligations on this Payment Bond, and it does hereby waive notice of any such change, extension of time, alteration or addition to the terms of the Contract or to the work or to the Specifications.

This Payment Bond shall be governed by and construed in accordance with the laws of the State of Maryland exclusive of its choice of laws rules and any reference herein to Principal or Surety in the singular shall include all entities in the plural who or which are signatories under the Principal or Surety heading below.

IN WITNESS WHEREOF, Principal and Surety have set their hands and seals to this Payment Bond. If any individual is a signatory under the Principal heading below, then each such individual has signed below on his or her own behalf, has set forth below the name of the firm, if any, in whose name he or she is doing business, and has set forth below his or her title as a sole proprietor. If any partnership or joint venture is a signatory under the Principal heading below, then all members of each such partnership or joint venture have signed below, each member has set forth below the name of the partnership or joint venture, and each member has set forth below his or her title as a general partner, limited partner, or member of joint venture, whichever is applicable. If any corporation is a signatory under the Principal or Surety heading below, then each such corporation has caused the following: The corporation’s name to be set forth below, a duly authorized representative of the corporation to affix below the corporation’s seal and to attach hereto a notarized corporate resolution or power of attorney authorizing such action, and each such duly authorized representative to sign any individual acts as a witness to any signature below, then each such individual has signed below and has set forth below his or her title as a witness. All of the above has been done as of the date of this Bond shown above.

---

In Presence of: Individual Principal  
Witness  
..... as to .....(SEAL)

---

In Presence of: Co-Partnership Principal  
Witness  
.....(SEAL)  
(Name of Co-Partnership)  
..... as to By:.....(SEAL)  
..... as to .....(SEAL)  
..... as to .....(SEAL)

---

Corporate Principal  
.....  
Attest: (Name of Corporation)  
.....  
Corporate Secretary By:..... AFFIX  
President CORPORATE  
SEAL

---

.....  
(Surety)  
Attest: (SEAL) By:..... AFFIX  
CORPORATE  
SEAL

.....  
Signature Title:.....

Bonding Agent's Name:.....  
(Business Address of Surety)

Agent's Address:.....

---

**HOWARD COUNTY, MARYLAND  
CONTRACTOR AGREEMENT**

THIS AGREEMENT ("Contract"), is made this \_\_\_\_\_ day of \_\_\_\_\_ in the year \_\_\_\_\_, by and between [ Insert Name of Contractor \_\_\_\_\_, Insert Contractor's Address \_\_\_\_\_, Insert Phone # \_\_\_\_\_ ] ("the Contractor"), and HOWARD COUNTY, MARYLAND, ("the County") as a result of Invitation for Bid No. \_\_\_\_\_ - \_\_\_\_\_.

**RECITALS**

This Agreement is subject to all the conditions, covenants, stipulations, terms and provisions contained in the Contract Documents as described in Paragraph 7 of this Agreement. The Contractor has been notified of award, for a sum equal to the aggregate cost of the work, labor, materials, and supplies done or furnished, at the prices and rates respectively named in the attached proposal (also referred to as Contractor's "Bid").

This Agreement fulfills the conditions of the Contract's award, which provides that a formal contract should be executed by and between the Contractor and the County evidencing the terms of the award.

**AGREEMENTS**

1. The Contractor covenants and agrees with the County that it will well and faithfully construct the project known as [ Insert Contract Title \_\_\_\_\_ ] work, in accordance with each and every one of the conditions, covenants, stipulations, terms and provisions contained in the Contract Documents, at and for a sum equal to the aggregate cost of the work, labor, materials, and supplies done and furnished at the prices and rates respectively named in the attached proposal. The Contractor further covenants and agrees that it will well and faithfully comply with and perform each and every obligation imposed upon him by the Contract Documents, or the terms of the award.

2. The Contractor covenants and agrees that its obligations pursuant to the Contract Documents include but are not limited to the furnishing of all material, labor, equipment, supplies, plant, tools, and all other services, facilities and expenses necessary for the full operational performance and completion of the requirements of the Contract Documents.

3. The County agrees that it will pay the Contractor, when due and payable under the terms of said Contract Documents and of said award, the sums set forth in Contractor's proposal, and the Contractor agrees that it will well and faithfully comply with and perform each and every obligation imposed upon it by this Agreement.

4. In no event shall the total compensation paid to the Contractor under this Agreement exceed the sum of \_\_\_\_\_ Dollars (\$ \_\_\_\_\_) during the entire term of this Agreement. [insert if applicable, including renewals thereof.]

5. The Contractor (if a corporation), hereby certifies that it is a Maryland corporation in good standing or a foreign corporation registered to do business in Maryland with the Maryland State Department of Assessments and Taxation.

6. The Contractor hereby certifies that it has read and understands the provisions of the Howard County Charter dealing with conflicts of interest.

7. The Contractor and County agree that the following enumerated documents, collectively referred to as Contract Documents, are all essential documents of this Agreement and are made a part hereof as if fully set forth herein:

- 7.1. Contractor Agreement
- 7.2. General Conditions for Construction and Applicable Addenda
- 7.3. Proposal and Special Provisions
- 7.4. Instructions to Bidders
- 7.5. Bid Form
- 7.6. Performance Bond No. \_\_\_\_\_
- 7.7. Labor and Materials Payment Bond No. \_\_\_\_\_
- 7.8. All Drawings and Specifications
- 7.9. All Addenda duly issued prior to submission of Bids
- 7.10. All Change Orders duly issued
- 7.11. Any amendments to the Contract duly executed by both parties, and
- 7.12. Additional documents listed on any Addendum attached hereto.

8. Ownership of Goods.

All finished or unfinished work, reports, or goods that are the subject of this Agreement; including any licenses or consents acquired by the Contractor for performance hereunder, shall be and shall remain the property of the County.

9. Term. All proposed work shall be completed within 120 calendar days from notice to proceed

10. Ethics.

SECTION E  
Invitation for Bid No. 2016-60

10.1 The Contractor certifies that the officer of the corporation who is executing this Agreement has read and understands Attachment A, entitled Howard County Charter and Code References to Ethics, which contains the provisions of Section 901(a) of the Howard County Charter dealing with conflicts of interest and Section 22.204 of the Howard County Code dealing with conflicts of interest.

10.2 The Contractor certifies that he/she has (1) not been a party to an agreement to bid a fixed or uniform price; (2) not offered nor will offer any gratuity to any county official or employee; and (3) not violated any of the fair employment provisions of Code Sec. 4.119 Ethics and Fair Employment Practices detailed in Attachment A.

11. Governing Law.

This Agreement shall be governed by and construed in accordance with the laws of the State of Maryland without regard to any choice of law principles that would dictate the laws of any other jurisdiction. The parties agree that the exclusive venue for any and all actions related hereto shall be the appropriate Federal or State court located within the State of Maryland.

This Agreement is made and entered into in Maryland and is to be construed under the laws of Maryland. As to the Contractor, this Agreement is intended to be a contract under seal and a specialty.

ATTEST:

APPROVED AND AGREED TO:  
[INSERT LEGAL NAME OF CONTRACTOR]

\_\_\_\_\_  
Secretary  
\_\_\_\_\_  
Print Name

By: \_\_\_\_\_(SEAL)  
Title: \_\_\_\_\_

ATTEST:

APPROVED:  
HOWARD COUNTY, MARYLAND

\_\_\_\_\_  
Lonnie R. Robbins  
Chief Administrative Officer

By: \_\_\_\_\_  
Allan H. Kittleman  
County Executive

APPROVED FOR LEGAL SUFFICIENCY:

\_\_\_\_\_  
Margaret Ann Nolan  
County Solicitor

REVIEWING ATTORNEY:

\_\_\_\_\_  
Type Name: \_\_\_\_\_  
Title: \_\_\_\_\_

APPROVED FOR SUFFICIENCY OF FUNDS:

DEPARTMENT APPROVED:

\_\_\_\_\_  
Stanley J. Milesky  
Director of Finance

\_\_\_\_\_  
James M. Irvin  
Director of Public Works

## ATTACHMENT A TO CONTRACTOR AGREEMENT

### HOWARD COUNTY CHARTER AND CODE REFERENCES TO ETHICS

#### *Charter Section 901. Conflict of Interest.*

(a) **Prohibitions.** No officer or employee of the County, whether elected or appointed, shall in any manner whatsoever be interested in or receive any benefit from the profits or emoluments of any contract, job, work, or service for the County. No such officer or employee shall accept any service or thing of value, directly or indirectly, from any person, firm or corporation having dealings with the County, upon more favorable terms than those granted to the public generally, nor shall he receive, directly or indirectly, any part of any fee, commission or other compensation paid or payable by the County, or by any person in connection with any dealings with the County, or by any person in connection with any dealings with or proceedings before any branch, office, department, board, commission or other agency of the County. No such officer or employee shall directly or indirectly be the broker or agent who procures or receives any compensation in connection with the procurement of any type of bonds for County officers, employees or persons or firms doing business with the County. No such officer or employee shall solicit or accept any compensation or gratuity in the form of money or otherwise for any act or omission in the course of his public work; provided, however, that the head of any department or board of the County may permit an employee to receive a reward publicly offered and paid for, for the accomplishment of a particular task.

(b) **Rules of construction; exceptions by Council.** The provisions of this Section shall be broadly construed and strictly enforced for the purpose of preventing officers and employees from securing any pecuniary advantages, however indirect, from their public associations, other than their compensation provided by law.

In order, however, to guard against injustice, the Council may, by resolution, specifically authorize any County officer or employee to own stock in any corporation or to maintain a business in connection with any person, firm or corporation dealing with the County, if, on full public disclosure of all pertinent facts to the County Council by such officer or employee, the Council shall determine that such stock ownership or connection does not violate the public interest.

The County Council may, by ordinance, delegate to the Howard County Ethics Commission the power to make such determinations and to authorize the ownership or connection. Any ordinance which delegates this power shall provide for procedures including a public hearing, and shall establish criteria for determining when the ownership or connection does not violate the public interest.

(c) **Penalties.** Any officer or employee of the County who willfully violates any of the provisions of this Section shall forfeit his office. If any person shall offer, pay, refund or rebate any part of any fee, commission, or other form of compensation to any officer or employee of the County in connection with any County business or proceeding, he shall, on conviction, be punishable by imprisonment for not less than one or more than six months or a fine of not less than \$100.00 or more than \$1,000.00, or both. Any contract made in violation of this Section may be declared void by the Executive or by resolution of the Council. The penalties in this Section shall be in addition to all other penalties provided by law.

#### *Code Section 4.119. Ethics and Fair Employment Practices.*

(a) **Conflict of Interest.** Bidders, vendors, purchasers and county employees involved in the purchasing process shall be governed by the provisions of the Howard County Charter and Howard County law regarding conflict of interest. No vendor shall offer a gratuity to an official or employee of the county. No official or employee shall accept or solicit a gratuity.

(b) **Discouragement of Uniform Bidding.**

(1) It is the policy of the county to discourage uniform bidding by every possible means and to endeavor to obtain full and open competition on all purchases and sales.

(2) No bidder may be a party with other bidders to an agreement to bid a fixed or uniform price.

(3) No person may disclose to another bidder, nor may a bidder acquire, prior to the opening of bids, the terms and conditions of a bid submitted by a competitor.

(c) **Fair Employment Practices**

(1) Bidders, vendors and purchases may not engage in unlawful employment practices as set forth in Subtitle 2 "human Rights" of Title 12 of the Howard County Code Section 14 of Article 49B of the Annotated Code of Maryland or Sections 703 and 704 of Title VII of the Civil Rights Act of 1964 as amended. Should any bidders, vendors or purchasers engage in such unlawful employment practices, they shall be subject to being declared irresponsible or being debarred pursuant to the provisions of this subtitle.

(2) The Howard County Office of Human Rights shall notify the county purchasing agent when any bidder is found, by a court of competent jurisdiction, to have engaged in any high unlawful employment practices.

(3) If any bidder has been declared to be an irresponsible bidder for having engaged in an unlawful employment practice and has been debarred from bidding pursuant to this subtitle, the Howard County Office of Human Rights shall review the employment practices of such bidder after the period of debarment has expired to determine if violations have been corrected and shall, within 30 days, file a report with the county purchasing agent informing the agent of such corrections before such bidder can be declared to be a responsible bidder by the County Purchasing agent.

(4) Payment of subcontractors. All contractors shall certify in writing that timely payments have been made to all subcontractors supplying labor and materials in accordance with the contractual arrangements made between the contractor and the subcontractors. No contractor will be paid a second or subsequent progress payment or final payment until such written certification is presented to the county purchasing agent.

**Code Section 22.204. - Prohibited Conduct and Interests.**

(a) **Participation Prohibitions.**

(1) Except as permitted by Commission regulation or opinion, an official or employee may not participate in:  
(i) Except in the exercise of an administrative or ministerial duty that does not affect the disposition or decision of the matter, any matter in which, to the knowledge of the official or employee, the official or employee or a qualified relative of the official or employee has an interest.

(ii) Except in the exercise of an administrative or ministerial duty that does not affect the disposition or decision with respect to the matter, any matter in which any of the following is a party:

a. A business entity in which the official or employee has a direct financial interest of which the official or employee may reasonably be expected to know;

b. A business entity for which the official, employee, or a qualified relative of the official or employee is an officer, director, trustee, partner, or employee;

c. A business entity with which the official or employee or, to the knowledge of the official or employee, a qualified relative is negotiating or has any arrangement concerning prospective employment;

d. If the contract reasonably could be expected to result in a conflict between the private interests of the official or employee and the official duties of the official or employee, a business entity that is a party to an existing contract with the official or employee, or which, to the knowledge of the official or employee, is a party to a contract with a qualified relative;

e. An entity, doing business with the County, in which a direct financial interest is owned by another entity in which the official or employee has a direct financial interest, if the official or employee may be reasonably expected to know of both direct financial interests; or

f. A business entity that:  
1. The official or employee knows is a creditor or obligee of the official or employee or a qualified relative of the official or employee with respect to a thing of economic value; and  
2. As a creditor or obligee, is in a position to directly and substantially affect the

interest of the official or employee or a qualified relative of the official or employee.

(2) A person who is disqualified from participating under paragraph 1. of this subsection shall disclose the nature and circumstances of the conflict and may participate or act if:

(i) The disqualification leaves a body with less than a quorum capable of acting;

(ii) The disqualified official or employee is required by law to act; or

(iii) The disqualified official or employee is the only person authorized to act.

(3) The prohibitions of paragraph 1 of this subsection do not apply if participation is allowed by regulation or opinion of the Commission.

(b) **Employment and Financial Interest Restrictions.**

(1) Except as permitted by regulation of the commission when the interest is disclosed or when the employment does not create a conflict of interest or appearance of conflict, an official or employee may not:

(i) Be employed by or have a financial interest in any entity:

a. Subject to the authority of the official or employee or the County agency, board, commission with which the official or employee is affiliated; or

b. That is negotiating or has entered a contract with the agency, board, or commission with which the official or employee is affiliated; or

(ii) Hold any other employment relationship that would impair the impartiality or independence of judgment of the official or employee.

(2) The prohibitions of paragraph (1) of this subsection do not apply to:

(i) An official or employee who is appointed to a regulatory or licensing authority pursuant to a statutory requirement that persons subject to the jurisdiction of the authority be represented in appointments to the authority;

(ii) Subject to other provisions of law, a member of a board or commission in regard to a financial interest or employment held at the time of appointment, provided the financial interest or employment is publicly disclosed to the appointing authority and the Commission;

(iii) An official or employee whose duties are ministerial, if the private employment or financial interest does not create a conflict of interest or the appearance of a conflict of interest, as permitted and in accordance with regulations adopted by the Commission; or

(iv) Employment or financial interests allowed by regulation of the Commission if the employment does not create a conflict of interest or the appearance of a conflict of interest or the financial interest is disclosed.

(c) **Post-Employment Limitations and Restrictions.**

(1) A former official or employee may not assist or represent any party other than the County for compensation in a case, contract, or other specific matter involving the County if that matter is one in which the former official or employee significantly participated as an official or employee.

(2) For a year after the former member leaves office, a former member of the County Council may not assist or represent another party for compensation in a matter that is the subject of legislative action.

(d) **Contingent Compensation.** Except in a judicial or quasi-judicial proceeding, an official or employee may not assist or represent a party for contingent compensation in any matter before or involving the County.

(e) **Use of Prestige of Office.**

(1) An official or employee may not intentionally use the prestige of office or public position for the private gain of that official or employee or the private gain of another.

(2) This subsection does not prohibit the performance of usual and customary constituent services by an elected official without additional compensation.

(f) **Solicitation and Acceptance of Gifts.**

(1) An official or employee may not solicit any gift.

(2) An official or employee may not directly solicit or facilitate the solicitation of a gift, on behalf of another person, from an individual regulated lobbyist.

(3) An official or employee may not knowingly accept a gift, directly or indirectly, from a person that the official or employee knows or has the reason to know:

- (i) Is doing business with or seeking to do business with the County office, agency, board or commission with which the official or employee is affiliated;
- (ii) Has financial interests that may be substantially and materially affected, in a manner distinguishable from the public generally, by the performance or nonperformance of the official duties of the official or employee;
- (iii) Is engaged in an activity regulated or controlled by the official's or employee's governmental unit; or
- (iv) Is a lobbyist with respect to matters within the jurisdiction of the official or employee.

(4) (i) Subsection (4)(ii) does not apply to a gift:  
a. That would tend to impair the impartiality and the independence of judgment of the official or employee receiving the gift;

b. Of significant value that would give the appearance of impairing the impartiality and independence of judgment of the official or employee; or  
c. Of significant value that the recipient official or employee believes or has reason to believe is designed to impair the impartiality and independence of judgment of the official or employee.

(ii) Notwithstanding paragraph (3) of this subsection, an official or employee may accept the following:  
a. Meals and beverages consumed in the presence of the donor or sponsoring entity;  
b. Ceremonial gifts or awards that have insignificant monetary value;  
c. Unsolicited gifts of nominal value that do not exceed \$20.00 in cost or trivial items of informational value;

d. Reasonable expenses for food, travel, lodging, and scheduled entertainment of the official or the employee at a meeting which is given in return for the participation of the official or employee in a panel or speaking engagement at the meeting;

e. Gifts of tickets or free admission extended to an elected official to attend a charitable, cultural, or political event, if the purpose of this gift or admission is a courtesy or ceremony extended to the elected official's office;

f. A specific gift or class of gifts that the Commission exempts from the operation of this subsection upon a finding, in writing, that acceptance of the gift or class of gifts would not be detrimental to the impartial conduct of the business of the County and that the gift is purely personal and private in nature;

g. Gifts from a person related to the official or employee by blood or marriage, or any other individual who is a member of the household of the official or employee; or

h. Honoraria for speaking to or participating in a meeting, provided that the offering of the honorarium is not related, in any way, to the official's or employee's official position.

(g) **Disclosure of Confidential Information.** Other than in the discharge of official duties, an official or employee may not disclose or use confidential information, that the official or employee acquired by reason of the official's or employee's public position and that is not available to the public, for the economic benefit of the official or employee or that of another person.

(h) **Participation in Procurement.**

(1) An individual or a person that employs an individual who assists a County, agency or unit in the drafting of specifications, an invitation for bids, or a request for proposals for a procurement, may not submit a bid or proposal for that procurement, or assist or represent another person, directly or indirectly, who is submitting a bid or proposal for the procurement.

(2) The Commission may establish exemptions from the requirements of this section for providing descriptive literature, sole source procurements, and written comments solicited by the procuring agency.

# **BID SUBMITTALS**

**HOWARD COUNTY, MARYLAND**  
**BID SUBMITAL CHECKLIST**  
**OAKLAND WATER TANK CLEANING AND COATING**

**NAME OF CONTRACTOR:** \_\_\_\_\_  
**(Please Print or Type)**

Is the company a certified Minority-, Women-, or Disabled-Owned Business Enterprise?  
 YES       NO

If yes, indicate the type of minority ownership:

- African American       Asian American       Disabled       Eskimo
- Female       Hispanic       Native American

If yes, indicate the certification(s) held:  
 Howard County Government     MD Dept. of Transportation     City of Baltimore     Other

Certification Number(s) and Expiration Date(s): \_\_\_\_\_

This package contains the following items:

- \_\_\_\_\_ BID FORMS (Including Total Amount of Bid form, Addendum Identification and Acknowledgment form and Schedule of Prices)
- \_\_\_\_\_ RAIN FOREST PROTECTION ACT OF 1991 CERTIFICATION
- \_\_\_\_\_ CORPORATION INFORMATION SHEET
- \_\_\_\_\_ QUALIFICATIONS QUESTIONNAIRE (Must be completed by all bidders)
- \_\_\_\_\_ AFFIDAVIT
- \_\_\_\_\_ FOREIGN SERVICES DISCLOSURE FORM
- \_\_\_\_\_ EQUAL BUSINESS OPPORTUNITY (EBO) SCHEDULE OF PARTICIPATION
- \_\_\_\_\_ WAGE RATE REQUIREMENTS FOR SERVICE CONTRACTS FORM
- \_\_\_\_\_ BID BOND OR CERTIFIED CHECK (Forms provided by the Bonding Agency)

THIS PACKAGE – SECTION F, MUST BE SUBMITTED IN DUPLICATE (1 ORIGINAL AND 1 COPY) TO THE OFFICE OF PURCHASING, GATEWAY BUILDING, 6751 COLUMBIA GATEWAY DRIVE, SUITE 501, COLUMBIA, MD 21046 BY:

March 16, 2016 PRIOR TO 2:00 P.M.

BIDDERS ARE REQUESTED TO SUBMIT THEIR BIDS IN A SEALED ENVELOPE PLAINLY MARKED TO INDICATE ITS CONTENTS OR IN AN ENVELOPE FURNISHED BY THE COUNTY AND TO ENTER THE PROJECT NAME, CAPITAL PROJECT NUMBER (CONTACT NUMBER IF APPLICABLE) AND BID OPENING TIME AND DATE ON THE ENVELOPE.

**HOWARD COUNTY, MARYLAND**

**TOTAL AMOUNT OF BID FORM**

**OAKLAND WATER TANK CLEANING AND COATING**

The Bidder declares that the only person, firm or corporation or persons, firms, or corporations that has or have any interest in this proposal or in the contract or contracts proposed to be taken, is or are the undersigned; that this proposal is made without any connection, collusion, or agreement with any person, firm, or corporation making a proposal for the same work to bid a fixed or uniform price, that the attached specifications and form of contract therein referred to have been carefully examined and are understood; that as careful an examination has been made as is necessary to become informed as to the character and extent of the work required; and that it is proposed and agreed if the proposal is accepted to contract with the Howard County, Maryland, Department of Public Works, in the form of contract hereto attached to do the required work in the manner set forth in the specifications.

Made this \_\_\_\_\_ day of \_\_\_\_\_, 20\_\_\_\_

\_\_\_\_\_  
(FIGURES) TOTAL AMOUNT OF BID

NAME OF CONTRACTOR \_\_\_\_\_

ADDRESS \_\_\_\_\_

SIGNED \_\_\_\_\_

NAME OF COMPANY OFFICIAL (Print or Type) \_\_\_\_\_

TITLE \_\_\_\_\_

TELEPHONE \_\_\_\_\_

EMAIL ADDRESS \_\_\_\_\_

FAX \_\_\_\_\_

All proposed work shall be completed within 244 calendar days from the date specified in the Notice to Proceed.

The amount of liquidated damages for this contract shall be \$500.00 per calendar day.

Accompanying this Proposal is a bid bond or certified check for 5% percent of the bid price payable to the "Director of Finance, Howard County", which is to be forfeited, as liquidated damages in the event that this Proposal is accepted and the above signed bidder shall refuse or neglect to execute the Contract and furnish the stipulated Bond under the conditions and time set forth in the Specifications.

**HOWARD COUNTY, MARYLAND**

**ADDENDUM IDENTIFICATION AND ACKNOWLEDGMENT**

**OAKLAND WATER TANK CLEANING AND COATING**

Bidder shall identify by number, date and number of pages the following addenda and agree that the costs shown in the proposal reflect all changes made by addenda.

| <u>NO.</u> | <u>Date</u> | <u>No. of Pages</u> |
|------------|-------------|---------------------|
| _____      | _____       | _____               |
| _____      | _____       | _____               |
| _____      | _____       | _____               |
| _____      | _____       | _____               |

NAME OF CONTRACTOR: \_\_\_\_\_

**HOWARD COUNTY, MARYLAND**

**SCHEDULE OF PRICES**

**OAKLAND WATER TANK CLEANING AND COATING**

COMPANY NAME: \_\_\_\_\_

| <b>A) Oakland Tank - Exterior</b>                            | Material | Labor Cost | Subtotal |
|--|----------|------------|----------|
| Exterior Blast   | \$       | \$         | \$       |
| Exterior Prim Coat   | \$       | \$         | \$       |
| Exterior Intermediate Coat                                   | \$       | \$         | \$       |
| Exterior Final Coat (Two Colors)                             | \$       | \$         | \$       |
| Rigging  | \$       | \$         | \$       |
| Tank Containment<br>(Installation, Maintenance and Removal)  | \$       | \$         | \$       |
| <b>A. Total Amount for Coating Oakland Exterior Surfaces</b> |          |            | \$       |

| <b>B) Oakland Tank Wet Interior</b>                              | Material | Labor Cost | Subtotal |
|--|----------|------------|----------|
| Interior Blast   | \$       | \$         | \$       |
| Interior Prim Coat   | \$       | \$         | \$       |
| Interior Intermediate Coat                                       | \$       | \$         | \$       |
| Interior Final Coat  | \$       | \$         | \$       |
| Rigging  | \$       | \$         | \$       |
| <b>B. Total Amount for Coating Oakland Interior Wet Surfaces</b> |          |            | \$       |

| <b>C) Oakland Tank Dry Interior - Coating</b>                    | Material | Labor Cost | Subtotal |
|--|----------|------------|----------|
| Interior Blast   | \$       | \$         | \$       |
| Interior Prim Coat   | \$       | \$         | \$       |
| Interior Intermediate Coat                                       | \$       | \$         | \$       |
| Interior Final Coat  | \$       | \$         | \$       |
| Rigging  | \$       | \$         | \$       |
| <b>C. Total Amount for Coating Oakland Interior Dry Surfaces</b> |          |            | \$       |

**HOWARD COUNTY, MARYLAND**

**SCHEDULE OF PRICES**

**OAKLAND WATER TANK CLEANING AND COATING**

COMPANY NAME: \_\_\_\_\_

| <b>D) Oakland Tank Dry Interior - Wash</b>                                 | Material | Labor Cost | Subtotal |
|--|----------|------------|----------|
| Pressure Wash Interior Wall of the Dry Riser                               | \$       | \$         | \$       |
| <b>D. Total Amount for Pressure Washing Interior Wall of the Dry Riser</b> |          |            | \$       |

| <b>E) Drip Edge</b>                               | Material | Labor Cost | Subtotal |
|---|----------|------------|----------|
| Fabricate, fit and install 3" drip edge, 280 feet | \$       | \$         | \$       |
| <b>E. Total Amount for Drip Edge</b>              |          |            | \$       |

| <b>F) Final Items</b>                  | Material | Labor Cost | Subtotal |
|--|----------|------------|----------|
| Cleanup and Site Restoration           | \$       | \$         | \$       |
| Overhead and Other Costs               | \$       | \$         | \$       |
| <b>F. Total Amount for Final Items</b> |          |            | \$       |

| <b>G) Discretionary</b>  |           |
|--|-----------|
| Amount set aside for necessary repairs or cleaning of county water tanks as determined and requested by the County's Project Manager and approved by the Director of Public Works or his designee. |           |
| <b>G. Total Amount for Discretionary Items</b>   | \$ 50,000 |

**H) Unit Items – Discretionary**

|   | Description                                     | Unit     | Price per Unit | Estimated Quantities | Price |
|---|---|----------|----------------|----------------------|-------|
| 1 | 8" angle; material, labor and installation      | per foot | \$             | 20                   | \$    |
| 2 | 6" angle; material, labor and installation      | per foot | \$             | 20                   | \$    |
| 3 | 4" angle; material, labor and installation      | per foot | \$             | 20                   | \$    |
| 4 | Ladder; material, fabrication and installation  | per foot | \$             | 20                   | \$    |
| 5 | Railing; material, fabrication and installation | per foot | \$             | 20                   | \$    |
| 6 | Plate metal patch, 8" wide                      | per foot | \$             | 20                   | \$    |
| 7 | Plate metal patch, 6" wide                      | per foot | \$             | 20                   | \$    |
| 8 | Plate metal patch, 4" wide                      | per foot | \$             | 20                   | \$    |

**HOWARD COUNTY, MARYLAND**

**SCHEDULE OF PRICES**

**OAKLAND WATER TANK CLEANING AND COATING**

|  | Description   | Unit         | Price per Unit | Estimated Quantities | Price |
|--|---|--------------|----------------|----------------------|-------|
| 9  | Demolition, removal of material and surface preparation not included in the above items | per man-hour | \$             | 20                   | \$    |
| 10                                       | Welding, not included in the above items  | per foot     | \$             | 20                   | \$    |
| 11                                       | Labor not included in the above items   | per man-hour | \$             | 20                   | \$    |
| <b>H. Estimated Total for Unit Items</b> |   |              |                |                      | \$    |

|  |             |  |
|--|-------------|--|
| TOTAL PART "A"                             | \$          |  |
| TOTAL PART "B"                             | \$          |  |
| TOTAL PART "C"                             | \$          |  |
| TOTAL PART "D"                             | \$          |  |
| TOTAL PART "E"                             | \$          |  |
| TOTAL PART "F"                             | \$          |  |
| TOTAL PART "G"                             | \$50,000.00 |  |
| TOTAL PART "H"                             | \$          |  |
| TOTAL FOR CONTRACT (PARTS A+B+C+D+E+F+G+H) | \$          |  |

**TOTAL BID PRICE\* Add (A) thru (H) Totals** \$ \_\_\_\_\_

Name of Welding and Metal Works: \_\_\_\_\_  
 \_\_\_\_\_  
 \_\_\_\_\_

\* This figure should appear as Total Bid Price, Price Page No. 1  
 \*\* Please note that prices shall only have **TWO DECIMAL PLACES**. The County's financial system will not allow more than two decimal places, adjust responses accordingly.

**INVOICE PROCEDURE FOR SUCCESSFUL CONTRACTORS:**

In order to facilitate prompt payment, invoices must contain the above commodity and/or service descriptions and pricing. Invoices failing to contain the required line item detail, including contract line number and unit pricing, may be returned for correction. Please submit a sample invoice with the response.

**HOWARD COUNTY, MARYLAND**  
**CORPORATION INFORMATION SHEET**

1. CORPORATE NAME: \_\_\_\_\_
2. CORPORATE ADDRESS: \_\_\_\_\_  
\_\_\_\_\_
3. PRINCIPAL BUSINESS OFFICE ADDRESS: \_\_\_\_\_  
\_\_\_\_\_  
TELEPHONE: \_\_\_\_\_ FAX: \_\_\_\_\_
4. NAME AND ADDRESS OF RESIDENT AGENT: \_\_\_\_\_
5. DATE OF INCORPORATION: \_\_\_\_\_ STATE OF INCORPORATION: \_\_\_\_\_
6. IF INCORPORATED IN ANOTHER STATE, IS CORPORATION REGISTERED AND QUALIFIED TO DO BUSINESS IN THE STATE OF MARYLAND? YES \_\_\_\_\_ NO \_\_\_\_\_
7. IS CORPORATION IN GOOD STANDING WITH THE STATE OF MARYLAND? YES \_\_\_\_\_ NO \_\_\_\_\_
8. IS THIS A CLOSE CORPORATION? YES \_\_\_\_\_ NO \_\_\_\_\_
9. MD STATE ASSESSMENT REGISTRATION NO.: \_\_\_\_\_
10. TAXPAYER IDENTIFICATION NUMBER: \_\_\_\_\_

Legal documents must be executed by the Corporate President or Vice President and the signature must be ATTESTED, not witnessed, by the Corporate Secretary or Assistant Secretary except in the case of a close corporation in which the signature may be witnessed. If someone other than the President or Vice President executes, the documents must be accompanied by a copy of Corporate By-Laws or Corporate Resolution indicating authority of individual to bind corporation.

11. NAME AND ADDRESSES OF ALL CURRENT OFFICERS (ATTACH INDIVIDUAL PAGES, IF NECESSARY):  
NAME & TITLE: \_\_\_\_\_  
ADDRESS: \_\_\_\_\_  
NAME & TITLE: \_\_\_\_\_  
ADDRESS: \_\_\_\_\_  
NAME & TITLE: \_\_\_\_\_  
ADDRESS: \_\_\_\_\_  
NAME & TITLE: \_\_\_\_\_  
ADDRESS: \_\_\_\_\_
12. NAMES AND ADDRESSES OF ALL CURRENT DIRECTORS (ATTACH ADDITIONAL PAGES, IF NECESSARY):  
\_\_\_\_\_  
\_\_\_\_\_  
\_\_\_\_\_  
(Authorized Signature) \_\_\_\_\_ (Date) \_\_\_\_\_  
(Type or Print Name) \_\_\_\_\_ (Title) \_\_\_\_\_

**HOWARD COUNTY, MARYLAND**

**QUALIFICATIONS QUESTIONNAIRE**

**OAKLAND WATER TANK CLEANING AND COATING**

**Name of Contractor:** \_\_\_\_\_ **Date:** \_\_\_\_\_

**Address:** \_\_\_\_\_

\_\_\_\_\_

**Telephone Number:** \_\_\_\_\_

**BIDDER'S/CONTRACTOR'S QUALIFICATIONS**

- 1 Bidders shall have at least 3 years of experience in the blasting, cleaning, and painting of water storage tanks and must have been actively engaged in this field for a period of not less than three continuous years. Additionally, all Contractors must have experience using the type of coating system specified and must possess necessary certifications. Bidders shall document this experience on the Qualifications Questionnaire (Section F), and provide a detailed list of recently completed projects meeting the specified experience requirements. The experience of owner(s) may be imputed to a newly formed company/contractor provided the owner(s) has/have at least 3 years of demonstrated experience of reliability and meets the criteria set forth herein.
- 2 The County reserves the right to inspect the Contractor's equipment and to perform such investigations as may be deemed necessary to insure that competent personnel and management will be utilized in the performance of the Agreement.
- 3 In accordance with Howard County Code Sec. 4.117 (a) (4), the quality of performance of previous contracts or services shall be considered in determining the lowest responsive and responsible bidder. Quality of performance may be determined through contracts or services provided to the County or to other entities. Quality of performance to other entities will be determined from reference checks when references are required. The determination of quality performance includes the Contractor's history of reasonable and cooperative behavior and commitment to customer satisfaction and the Contractor's businesslike concern for the interests of the customer. The County reserves the right to reject any bid deemed not responsible or non-responsive.
- 4 All Contractors shall have successfully blasted, cleaned, and coated the interior and/or exterior of at least four elevated water tanks.
- 5 All Contractors shall have experience with abrasive blasting, high pressure washing, and coatings application.
- 6 All Contractors shall have successfully installed and maintained a tank containment system on at least three elevated water tanks.

- 7 All Contractors must provide an on-site foreman or lead painter who possesses a minimum of five years' experience in the field of water tank coating. This person must remain on-site during the entire work effort.
  - 7.1 The name of the on-site foreman or lead painter as well as contact information shall be listed with the bid documents.
  - 7.2 The foreman or lead painter selected shall have successfully blasted, cleaned, and coated the interior and exterior of at least three water tanks of similar type and size to the tank. Also, this person shall have experience with abrasive blasting, high pressure washing, and coatings application. This experience shall be document on the "Experience and Qualification Sheet" for the foreman and/or lead painter, Bid Document "F".
  - 7.3 The on-site foreman or lead painter shall have experience with the coating systems specified for use and shall have a thorough knowledge of all aspects of the specific work effort.
  - 7.4 The name of a firm to be used for welding and metal working.
- 8 No contract shall be awarded to other than a responsible Contractor meeting all the requirements of these specifications. The County reserves the right to reject all bids if none are deemed fully compliant.
- 9 The County reserves the right to inspect the Contractor's equipment at a convenient site and to perform such investigation as deemed necessary to insure that competent personnel and management will be utilized in the performance of this contract.
- 10 The County reserves the right to check all references furnished and, if deemed necessary by the County, visit sites to verify previous work performed, and consider the responses received in determining award of this bid.
- 11 Any false information furnished on or with the Contractor's submittal may be cause for rejection of the bid.

**SECTION F**  
**CONTRACTOR'S QUALIFICATION INFORMATION**

COMPANY NAME: \_\_\_\_\_

1. References: Give name, address, and telephone number of owner or manager of three accounts for which Contractor has provided blasting, cleaning, and painting of water storage tanks during the past three years. Additionally, all Contractors must have experience using the type of coating material systems specified and must possess necessary certifications.

|      |               |                          |
|------|---------------|--------------------------|
| 1.1. | Account Name  | Contract Completion Date |
|      | _____         | _____                    |
|      | Owner/Manager | Telephone                |
|      | _____         | _____                    |
|      | Address       | Email                    |
|      | _____         | _____                    |
|      | _____         | _____                    |
| 1.2. | Account Name  | Contract Completion Date |
|      | _____         | _____                    |
|      | Owner/Manager | Telephone                |
|      | _____         | _____                    |
|      | Address       | Email                    |
|      | _____         | _____                    |
|      | _____         | _____                    |
| 1.3. | Account Name  | Contract Completion Date |
|      | _____         | _____                    |
|      | Owner/Manager | Telephone                |
|      | _____         | _____                    |
|      | Address       | Email                    |
|      | _____         | _____                    |
|      | _____         | _____                    |

2. The Contractor has provided the above services for \_\_\_\_ years. (Note: three year minimum)

**FOREMAN QUALIFICATION INFORMATION**

COMPANY NAME: \_\_\_\_\_

FOREMAN NAME: \_\_\_\_\_

1. References: Give name, address, and telephone number of owner or manager of three accounts for which foreman has supervised blasting, cleaning, and painting of water storage tanks during the past three years. Additionally, all foremen must have experience using the type of coating material systems specified and must possess necessary certifications.

1.1. Account Name \_\_\_\_\_ Contract Completion Date \_\_\_\_\_

Owner/Manager

Telephone

Address

Email

1.2. Account Name \_\_\_\_\_ Contract Completion Date \_\_\_\_\_

Owner/Manager

Telephone

Address

Email

1.3. Account Name \_\_\_\_\_ Contract Completion Date \_\_\_\_\_

Owner/Manager

Telephone

Address

Email

2. The Foreman has supervised the above services for \_\_\_\_ years. (Note: three year minimum)

**SECTION F**  
**LEAD PAINTER QUALIFICATION INFORMATION**

COMPANY NAME: \_\_\_\_\_

1. References: Give name, address, and telephone number of owner or manager of three accounts for which Lead Painter has coated the interior and exterior of an elevated water tank which included blasting, cleaning, and painting of water storage tanks during the past three years. Additionally, all Contractors must have experience using the type of coating material systems specified and must possess necessary certifications.

|      |               |                          |
|------|---------------|--------------------------|
| 1.1. | Account Name  | Contract Completion Date |
|      | _____         | _____                    |
|      | Owner/Manager | Telephone                |
|      | _____         | _____                    |
|      | Address       | Email                    |
|      | _____         | _____                    |
|      | _____         | _____                    |

|      |               |                          |
|------|---------------|--------------------------|
| 1.2. | Account Name  | Contract Completion Date |
|      | _____         | _____                    |
|      | Owner/Manager | Telephone                |
|      | _____         | _____                    |
|      | Address       | Email                    |
|      | _____         | _____                    |
|      | _____         | _____                    |

|      |               |                          |
|------|---------------|--------------------------|
| 1.3. | Account Name  | Contract Completion Date |
|      | _____         | _____                    |
|      | Owner/Manager | Telephone                |
|      | _____         | _____                    |
|      | Address       | Email                    |
|      | _____         | _____                    |
|      | _____         | _____                    |

2. The Lead Painter has provided the above services for \_\_\_\_ years. (Note: three year minimum)

1. **BIDDER'S CONSTRUCTION EXPERIENCE**, list most recent first.

(a) **Most Recent Work:**

**Work for which Bidder was responsible:**

Project Title and/or Other Identifying Number for the Work: \_\_\_\_\_

Location (Street Address, City/County, State): \_\_\_\_\_

Start Construction Date \_\_\_\_\_ End Construction Date: \_\_\_\_\_

Bidder's total dollar amount for the Work described: \_\_\_\_\_

Bidder's Superintendent for the Work: \_\_\_\_\_

Bidder's Project Manager for the Work: \_\_\_\_\_

**Agency or Firm for whom work was performed (the Owner):**

Name: \_\_\_\_\_

Address: \_\_\_\_\_

Telephone Number: \_\_\_\_\_

Names of persons having supervisory responsibility within Agency or Firm for whom Work was performed: \_\_\_\_\_

**Firm performing Engineering Inspection Services:**

Name: \_\_\_\_\_

Address: \_\_\_\_\_

Telephone Number: \_\_\_\_\_

Names of persons having supervisory responsibility within firm performing Engineering Inspection Services: \_\_\_\_\_

**Was the Work of the Bidder performed as a Subcontractor? \_\_\_\_\_ (yes), \_\_\_\_\_ (no)**

If "yes" Bidder shall complete the following:

Name of Prime Contractor: \_\_\_\_\_

Address of Prime Contractor: \_\_\_\_\_

Telephone No. of Prime Contractor: \_\_\_\_\_

Names of persons having supervisory responsibility within the Prime Contractor's firm for whom the Work was performed: \_\_\_\_\_

Other pertinent information regarding this project:

\_\_\_\_\_  
\_\_\_\_\_  
\_\_\_\_\_  
\_\_\_\_\_  
\_\_\_\_\_

1. **BIDDER'S CONSTRUCTION EXPERIENCE (continued)**, list most recent first.

(b) **Next Most Recent Work:**

**Work for which Bidder was responsible:**

Project Title and/or Other Identifying Number for the Work: \_\_\_\_\_

Location (Street Address, City/County, State): \_\_\_\_\_

Start Construction Date \_\_\_\_\_ End Construction Date: \_\_\_\_\_

Bidder's total dollar amount for the Work described: \_\_\_\_\_

Bidder's Superintendent for the Work: \_\_\_\_\_

Bidder's Project Manager for the Work: \_\_\_\_\_

**Agency or Firm for whom work was performed (the Owner):**

Name: \_\_\_\_\_

Address: \_\_\_\_\_

Telephone Number: \_\_\_\_\_

Names of persons having supervisory responsibility within Agency or Firm for whom Work was performed: \_\_\_\_\_

**Firm performing Engineering Inspection Services:**

Name: \_\_\_\_\_

Address: \_\_\_\_\_

Telephone Number: \_\_\_\_\_

Names of persons having supervisory responsibility within firm performing Engineering Inspection Services: \_\_\_\_\_

**Was the Work of the Bidder performed as a Subcontractor? \_\_\_\_\_ (yes), \_\_\_\_\_ (no)**

If "yes" Bidder shall complete the following:

Name of Prime Contractor: \_\_\_\_\_

Address of Prime Contractor: \_\_\_\_\_

Telephone No. of Prime Contractor: \_\_\_\_\_

Names of persons having supervisory responsibility within the Prime Contractor's firm for whom the Work was performed: \_\_\_\_\_

Other pertinent information regarding this project:

\_\_\_\_\_  
\_\_\_\_\_  
\_\_\_\_\_  
\_\_\_\_\_  
\_\_\_\_\_

1. **BIDDER'S CONSTRUCTION EXPERIENCE (continued)**, list most recent first.

(c) **Next Most Recent Work:**

**Work for which Bidder was responsible:**

Project Title and/or Other Identifying Number for the Work: \_\_\_\_\_

Location (Street Address, City/County, State): \_\_\_\_\_

Start Construction Date \_\_\_\_\_ End Construction Date: \_\_\_\_\_

Bidder's total dollar amount for the Work described: \_\_\_\_\_

Bidder's Superintendent for the Work: \_\_\_\_\_

Bidder's Project Manager for the Work: \_\_\_\_\_

**Agency or Firm for whom work was performed (the Owner):**

Name: \_\_\_\_\_

Address: \_\_\_\_\_

Telephone Number: \_\_\_\_\_

Names of persons having supervisory responsibility within Agency or Firm for whom Work was performed: \_\_\_\_\_

**Firm performing Engineering Inspection Services:**

Name: \_\_\_\_\_

Address: \_\_\_\_\_

Telephone Number: \_\_\_\_\_

Names of persons having supervisory responsibility within firm performing Engineering Inspection Services: \_\_\_\_\_

**Was the Work of the Bidder performed as a Subcontractor? \_\_\_\_\_ (yes), \_\_\_\_\_ (no)**

If "yes" Bidder shall complete the following:

Name of Prime Contractor: \_\_\_\_\_

Address of Prime Contractor: \_\_\_\_\_

Telephone No. of Prime Contractor: \_\_\_\_\_

Names of persons having supervisory responsibility within the Prime Contractor's firm for whom the Work was performed: \_\_\_\_\_

Other pertinent information regarding this project:

\_\_\_\_\_  
\_\_\_\_\_  
\_\_\_\_\_  
\_\_\_\_\_  
\_\_\_\_\_

1. **BIDDER'S CONSTRUCTION EXPERIENCE (continued)**, list most recent first.

(d) **Next Most Recent Work:**

**Work for which Bidder was responsible:**

Project Title and/or Other Identifying Number for the Work: \_\_\_\_\_

Location (Street Address, City/County, State): \_\_\_\_\_

Start Construction Date \_\_\_\_\_ End Construction Date: \_\_\_\_\_

Bidder's total dollar amount for the Work described: \_\_\_\_\_

Bidder's Superintendent for the Work: \_\_\_\_\_

Bidder's Project Manager for the Work: \_\_\_\_\_

**Agency or Firm for whom work was performed (the Owner):**

Name: \_\_\_\_\_

Address: \_\_\_\_\_

Telephone Number: \_\_\_\_\_

Names of persons having supervisory responsibility within Agency or Firm for whom Work was performed: \_\_\_\_\_

**Firm performing Engineering Inspection Services:**

Name: \_\_\_\_\_

Address: \_\_\_\_\_

Telephone Number: \_\_\_\_\_

Names of persons having supervisory responsibility within firm performing Engineering Inspection Services: \_\_\_\_\_

**Was the Work of the Bidder performed as a Subcontractor? \_\_\_\_\_ (yes), \_\_\_\_\_ (no)**

If "yes" Bidder shall complete the following:

Name of Prime Contractor: \_\_\_\_\_

Address of Prime Contractor: \_\_\_\_\_

Telephone No. of Prime Contractor: \_\_\_\_\_

Names of persons having supervisory responsibility within the Prime Contractor's firm for whom the Work was performed: \_\_\_\_\_

Other pertinent information regarding this project:

\_\_\_\_\_  
\_\_\_\_\_  
\_\_\_\_\_  
\_\_\_\_\_  
\_\_\_\_\_

1. **BIDDER'S CONSTRUCTION EXPERIENCE (continued)**, list most recent first.

(e) **Next Most Recent Work:**

**Work for which Bidder was responsible:**

Project Title and/or Other Identifying Number for the Work: \_\_\_\_\_

Location (Street Address, City/County, State): \_\_\_\_\_

Start Construction Date \_\_\_\_\_ End Construction Date: \_\_\_\_\_

Bidder's total dollar amount for the Work described: \_\_\_\_\_

Bidder's Superintendent for the Work: \_\_\_\_\_

Bidder's Project Manager for the Work: \_\_\_\_\_

**Agency or Firm for whom work was performed (the Owner):**

Name: \_\_\_\_\_

Address: \_\_\_\_\_

Telephone Number: \_\_\_\_\_

Names of persons having supervisory responsibility within Agency or Firm for whom Work was performed: \_\_\_\_\_

**Firm performing Engineering Inspection Services:**

Name: \_\_\_\_\_

Address: \_\_\_\_\_

Telephone Number: \_\_\_\_\_

Names of persons having supervisory responsibility within firm performing Engineering Inspection Services: \_\_\_\_\_

**Was the Work of the Bidder performed as a Subcontractor? \_\_\_\_\_ (yes), \_\_\_\_\_ (no)**

If "yes" Bidder shall complete the following:

Name of Prime Contractor: \_\_\_\_\_

Address of Prime Contractor: \_\_\_\_\_

Telephone No. of Prime Contractor: \_\_\_\_\_

Names of persons having supervisory responsibility within the Prime Contractor's firm for whom the Work was performed: \_\_\_\_\_

Other pertinent information regarding this project:

\_\_\_\_\_  
\_\_\_\_\_  
\_\_\_\_\_  
\_\_\_\_\_  
\_\_\_\_\_





**HOWARD COUNTY, MARYLAND**

**AFFIDAVIT**

(Must be completed, signed, and submitted with the bid.)

**OAKLAND WATER TANK CLEANING AND COATING**

Contractor \_\_\_\_\_

Address \_\_\_\_\_

I, \_\_\_\_\_, the undersigned, \_\_\_\_\_ of the above named  
(Print Signer's Name) (Print Office Held)

Contractor does declare and affirm this \_\_\_\_\_ day of \_\_\_\_\_, \_\_\_\_\_, that I hold the aforementioned office  
(Month) (Year)  
in the above named Contractor and I affirm the following:

**AFFIDAVIT I**

The Contractor, his Agent, servants and/or employees, have not in any way colluded with anyone for and on behalf of the Contractor or themselves, to obtain information that would give the Contractor an unfair advantage over others, nor have they colluded with anyone for and on behalf of the Contractor, or themselves, to gain any favoritism in the award of the contract herein.

**AFFIDAVIT II**

No officer or employee of Howard County, whether elected or appointed, has in any manner whatsoever, any interest in or has received prior hereto or will receive subsequent hereto any benefit, monetary or material, or consideration from the profits or emoluments of this contract, job, work or service for the County, and that no officer or employee has accepted or received or will receive in the future a service or thing of value, directly or indirectly, upon more favorable terms than those granted to the public generally, nor has any such officer or employee of the County received or will receive, directly or indirectly, any part of any fee, commission or other compensation paid or payable to the County in connection with this contract, job, work, or service for the County, excepting, however, the receipt of dividends on corporation stock.

**AFFIDAVIT III**

Neither I, nor the Contractor, nor any officer, director, or partners, or any of its employees who are directly involved in obtaining contracts with Howard County have been convicted of bribery, attempted bribery, or conspiracy to bribe under the laws of any state, or of the federal government for acts of omissions committed after July 1, 1977.

**AFFIDAVIT IV**

Neither I, nor the Contractor, nor any of our agents, partners, or employees who are directly involved in obtaining contracts with Howard County have been convicted within the past 12 months of discrimination against any employee or applicant for employment, nor have we engaged in unlawful employment practices as set forth in Section 12.200 of the Howard County Code, or of Section 16 of Article 49B of the Annotated Code of Maryland or, of Sections 703 and 704 of Title VII of the Civil Rights Act of 1964.

**AFFIDAVIT V**

The Contractor:

- i. Is not currently identified on the list created by the Maryland State Board of Public Works as a person engaging in investment activities in Iran as described in Section 17-702 of the *Maryland State Finance and Procurement Article* ; or
- ii. Is not currently engaging in investment activities in Iran as described in Section 17-702 of the *Maryland State Finance and Procurement Article*.

If the person is unable to make the certification, it will provide the County, a detailed description of the Contractor's investment activities in Iran.

I do solemnly declare and affirm under the penalties of perjury that the contents of the foregoing affidavits are true and correct to the best of my knowledge, information and belief.

\_\_\_\_\_  
Signature

\_\_\_\_\_  
Printed Name

\_\_\_\_\_  
Title

## EQUAL BUSINESS OPPORTUNITY PARTICIPATION

### **NOTICE TO PRIME CONTRACTORS 10% SUBCONTRACTING GOAL ON CONTRACTS VALUED AT \$50,000 OR MORE**

Howard County Code Section 4.122 established an Equal Business Opportunity program to foster overall equity and fairness to all citizens in relation to business enterprises conducting business with the County.

If a contract is \$50,000 or more, the Prime Contractor shall make a good faith effort to comply with the Howard County Equal Business Opportunity (EBO) program's 10% subcontracting goal. The Prime Contractor shall make a good faith effort to obtain minority subcontractor participation even if the Prime Contractor has the capability to complete the work with its own workforce. This is also applicable to Prime Contractors that are minority-owned firms. The percentage requirement may vary. Prime Contractors should submit the following completed *Equal Business Opportunity Subcontractor Participation Form* with the bid. Identify subcontractors prior to submitting the proposal. After contract award, changes in subcontractors require the written approval of the EBO Coordinator.

Possible areas of obtaining subcontracting participation include, but are not limited to, flagging services, hauling, copying and printing, and the purchase of materials used in performing the contract. Contractors may use minority, women or disabled business enterprises certified by Howard County, Maryland; the Maryland Department of Transportation; the City of Baltimore, Maryland; or another certifying entity in order to satisfy the 10% subcontracting goal. The website addresses for lists of minority businesses are:

[Howard County - Equal Business Opportunity List of Firms A-Z](http://www.md.gov/ebo)  
[http://www.mdot.state.md.us/MBE\\_Program/index.html](http://www.mdot.state.md.us/MBE_Program/index.html)  
<http://cityservices.baltimorecity.gov/mwboo>

Contractors should submit a completed *Equal Business Opportunity Subcontractor Participation Form* with the bid identifying each certified EBO firm they intend to use on the contract. However, if the EBO Subcontractor Participation Form is not submitted with the bid, the County may request EBO subcontractor participation of the successful contractor.

Contractors failing to achieve the Equal Business Opportunity Program goal following a good faith effort to obtain participation must complete the *Equal Business Opportunity Program Request for Subcontracting Waiver* and provide documentation of its good faith attempts to obtain EBO participation. The County will determine if the efforts made satisfy a good faith attempt. A waiver will only be considered in rare contracts after a determination that the Contractor has made a good faith effort and thoroughly documented the efforts. Contractors should submit the *Equal Business Opportunity Program Request for Subcontracting Waiver* with the bid. However, if the request for waiver form is not submitted with the bid, the County may obtain the request for waiver of the successful contractor.

If the County exercises its option to renew the contract, it is expected that the EBO subcontracting goal will be met for each subsequent contract year when the contract amount is \$50,000.00 or more. Questions relating to the EBO program shall be directed to the EBO Coordinator 410-313-6370.

### **PRIME CONTRACTORS' COMPLIANCE OF EBO SUBCONTRACTOR PARTICIPATION**

Prime Contractors that are awarded County contracts shall maintain adequate records of EBO participation on County contracts. The County may require that prime contractors report whether or not they met the proposed EBO subcontracting goal, so that the County can track compliance of EBO participation on County contracts.



**HOWARD COUNTY, MARYLAND  
 EQUAL BUSINESS OPPORTUNITY (EBO)  
 SUBCONTRACTOR PARTICIPATION FORM**

COUNTY USE ONLY  
 EBO APPROVAL

|  |                          |                        |
|--|--------------------------|------------------------|
| <b>CONTRACT TITLE: OAKLAND WATER TANK CLEANING AND COATING</b> |                          |                        |
| <b>SOLICITATION # IFB 2016-60</b>                              | <b>CAPITAL PROJECT #</b> | <b>CONTRACT / PO #</b> |
| <b>TERM:</b>   | <b>RENEWAL #</b>         | <b>AMOUNT \$</b>       |

|                               |                   |                           |
|-------------------------------|-------------------|---------------------------|
| <b>PRIME CONTRACTOR NAME:</b> |                   |                           |
| <b>ADDRESS:</b>               |                   | <b>PHONE:</b>             |
| <b>EBO STATUS (Y/N):</b>      | <b>*EBO TYPE:</b> | <b>CERTIFYING AGENCY:</b> |
|                               |                   | <b>CERTIFICATION #</b>    |

**PRIME CONTRACTOR SHOULD LIST ALL EBO SUBCONTRACTORS / SUBCONSULTANTS / SUPPLIERS**

**INSTRUCTIONS FOR COMPLETING THIS FORM**

- Complete the section below identifying each certified EBO firm (Minority (MBE), Woman (WBE), and Disabled (DBE) Business Enterprises) you intend to use on this project. Attach additional sheets if more than two (2) subcontractors.
- This form represents the contractor's commitment to utilize the named EBO firms at the percentages indicated should the contract be awarded to the contractor. This form should accompany your bid or proposal.
- **\*EBO Types:** AA (African American), ASA (Asian American), HIS (Hispanic American), NA (Native American), FEM (Female), DIS (Disabled)

|                                |                              |                              |
|--------------------------------|------------------------------|------------------------------|
| <b>SUBCONTRACTOR NAME:</b>     |                              |                              |
| <b>ADDRESS:</b>                |                              | <b>PHONE:</b>                |
| <b>CONTACT REPRESENTATIVE:</b> |                              | <b>EMAIL:</b>                |
| <b>*EBO TYPE (Check One)</b>   | <input type="checkbox"/> AA  | <input type="checkbox"/> ASA |
|                                | <input type="checkbox"/> HIS | <input type="checkbox"/> NA  |
|                                | <input type="checkbox"/> FEM | <input type="checkbox"/> DIS |
| <b>CERTIFYING AGENCY:</b>      | <b>CERTIFICATION #</b>       | <b>EBO PARTICIPATION %</b>   |
| <b>DESCRIPTION OF WORK:</b>    |                              | <b>EBO PARTICIPATION \$</b>  |

|                                |                              |                              |
|--------------------------------|------------------------------|------------------------------|
| <b>SUBCONTRACTOR NAME:</b>     |                              |                              |
| <b>ADDRESS:</b>                |                              | <b>PHONE:</b>                |
| <b>CONTACT REPRESENTATIVE:</b> |                              | <b>EMAIL:</b>                |
| <b>*EBO TYPE (Check One)</b>   | <input type="checkbox"/> AA  | <input type="checkbox"/> ASA |
|                                | <input type="checkbox"/> HIS | <input type="checkbox"/> NA  |
|                                | <input type="checkbox"/> FEM | <input type="checkbox"/> DIS |
| <b>CERTIFYING AGENCY:</b>      | <b>CERTIFICATION #</b>       | <b>EBO PARTICIPATION %</b>   |
| <b>DESCRIPTION OF WORK:</b>    |                              | <b>EBO PARTICIPATION \$</b>  |

\_\_\_\_\_  
 PRINTED NAME

\_\_\_\_\_  
 EMAIL

\_\_\_\_\_  
 SIGNATURE (VENDOR OFFICIAL)

\_\_\_\_\_  
 TITLE  
 Page 2 of 3

\_\_\_\_\_  
 DATE  
 Revised 12/20/2013

**HOWARD COUNTY, MARYLAND**  
**EQUAL BUSINESS OPPORTUNITY**  
**REQUEST FOR SUBCONTRACTING WAIVER**

**NAME OF CONTRACTOR:** \_\_\_\_\_

**TITLE:** \_\_\_\_\_

**SOLICITATION NUMBER:** \_\_\_\_\_

I do hereby request that an exception be granted to the requirement that a minimum of percent of the total value of this contract be placed with MBE/WBE/DBE firms.

In connection with the above captioned project, and this request, I hereby certify that I am the \_\_\_\_\_  
(TITLE)

and duly authorized representative of \_\_\_\_\_  
(COMPANY NAME)

at \_\_\_\_\_  
(ADDRESS)

I further certify that I have enclosed a Schedule of Participation by MBE/WBE/DBE firms, which reflects the percentage and dollar value of MBE/WBE/DBE participation, which my company expects to achieve for this contract. That percentage is \_\_\_\_\_ and the dollar value is \$\_\_\_\_\_.

Therefore, the Request for Exception is for \_\_\_\_\_percentage and \$\_\_\_\_\_ dollar value.

To support this Request for Exception, I include the following information as attachments, which I certify to be true to the best of my knowledge, information and belief (Include the following. Use as many pages as necessary):

1. A statement of the efforts made by your company to contact and negotiate with MBE/WBE/DBE firms, including the names, addresses, and telephone numbers of MBE/WBE/DBE firms contacted and a description of the information provided to MBE/WBE/DBE firms regarding the plans and specifications for portions of the work to be performed.
2. A statement of the efforts made by your company to select portions of the work proposed to be performed by MBE/WBE/DBE firms in order to increase the likelihood of achieving the stated goal.
3. For each MBE/WBE/DBE firm which placed a bid which your company considers to be unacceptable, submit a statement which explains the basis for your conclusion that the MBE/WBE/DBE firm is unacceptable.

\_\_\_\_\_  
(SIGNATURE)

\_\_\_\_\_  
(DATE)

## INFORMATION ON HOWARD COUNTY, MARYLAND'S LIVING WAGE REQUIREMENT

### Basics of the Howard County Living Wage Legislation

In 2007, the Howard County Council passed legislation requiring a minimum "living wage" for employees of certain contractors and subcontractors of Howard County. A Contractor that is defined as a "Covered Employer" under Howard County Code Section 4.122A shall pay each employee an hourly rate sufficient to at least equal 125% of the federal poverty guidelines for a family of four individuals calculated on the basis of a 40-hour work week for 52 weeks.

Howard County Code Sec. 4.122A applies to service contracts estimated to be over \$100,000.00 per year. The code does not apply to commodities contracts, contractors who employ fewer than 5 employees during the contract term, public entities, non-profit organizations, or contracts awarded under sole source, emergency, or expedited procedures. Other contractors may also be exempt; see the complete list of exemptions in Section 1 on the front of this form.

The living wage requirements do not apply to an employee:

- who performs no measurable work related to any contract with the County
- who participates in a government-operated or government-sponsored program that restricts the earnings of or wages paid to employees to a level below the wage required under the law
- who participates for not longer than 120 days in a calendar year in a government-operated or government-sponsored summer youth employment program
- for whom a different wage rate is expressly set in a collective bargaining agreement, or
- for whom a higher wage is required by a federal, state, or County law.

This form serves as written certification to the County of your firm's intent to comply with the County's wage requirements during this term and any subsequent renewals. A Covered Employer shall not subdivide a contract; pay an employee through a third party; or treat an employee as a subcontractor or independent Contractor to avoid the imposition of any requirement under this law. Failure to comply with this requirement at any time during the initial term and subsequent renewals may be sufficient cause for termination for default. A violation of this law is a Class A civil offense; in addition to a fine, the County may suspend or debar the violator under Howard County Code Sec. 4.117.

### Current Living Wage Rate in Howard County

As of January 28, 2016, the Living Wage Rate is **\$14.60 per hour**.

### How the Living Wage Rate is Calculated

The Howard County Living Wage Rate is calculated by taking 125% of the Federal Poverty Guideline for a family of 4, then using this amount to determine the hourly rate based on 40 hours/week. For example, on January 25, 2016, the Federal HHS Poverty Guideline was published as \$24,300 for a family of 4 (see [www.aspe.hhs.gov/poverty](http://www.aspe.hhs.gov/poverty)).

$$125\% \text{ of } \$24,300 = \$30,375.00 \quad \$30,375.00 \div 52 \text{ weeks} \div 40 \text{ hrs/week} = \mathbf{\$14.60 \text{ per hour}}$$

This hourly rate must be paid to employees (full-time or part-time) during the time the employees actually provide services to the County. The current Living Wage remains in effect until new federal poverty guidelines are published, which is usually the following January. If there is a change, the Office of Purchasing will attempt to notify all current contractors via email using the email address provided on this form. The current rate is posted on our website at [www.howardcountymd.gov/purchasing](http://www.howardcountymd.gov/purchasing). It is the contractor's responsibility to ascertain the current rate.

**Since the rate is subject to change annually, you must ensure that your bid pricing is sufficient to cover the cost of any increases during the term of the contract, including subsequent renewals.** All prices shall take the current wage rate, and subsequent increases in the wage rate, if any, into account and there shall be no unit price adjustment for future wage rate increases during the initial term of this agreement and any subsequent renewals thereof. Future wage rate increases are hereby defined as any new rates approved by the County that take effect after and supersede the rate shown in this solicitation.

**If you have questions about the Living Wage Requirement or how to complete this form, please contact the Office of Purchasing at [purchasing@howardcountymd.gov](mailto:purchasing@howardcountymd.gov) or 410-313-6370.**

**Howard County, Maryland Wage Rate Requirements for Service Contracts  
Exemption Status Subtitle 1, Howard County Code Section 4.122A(b)(2)**

| Prime Contr.             | Sub-Contr.               | Section 1: Exemption  | Check all that apply, then continue to Section 2. If none of these statements apply to your company or the Subcontractor, check the last box in this section and continue to Section 2. |
|--------------------------|--------------------------|---|---|
| <input type="checkbox"/> | <input type="checkbox"/> | Contractor or Subcontractor employs fewer than 5 employees at any time during the contract term.  |   |
| <input type="checkbox"/> | <input type="checkbox"/> | Contractor or Subcontractor received less than \$100,000 from the County in the most recent 12- month period prior to the start date, and will be entitled to receive less than \$100,000 from the County within the next 12-month period.  |   |
| <input type="checkbox"/> | <input type="checkbox"/> | Contractor or Subcontractor is a nonprofit organization that has qualified for an exemption from federal income taxes under Section 501(c)(3) of the Internal Revenue Code.   |   |
| <input type="checkbox"/> | <input type="checkbox"/> | Contractor or Subcontractor is expressly precluded from complying with Howard County Code Sec. 4.122A by the terms of any federal, state, or county law, federal or state contract or grant, and the contract falls within that preclusion. |   |
| <input type="checkbox"/> | <input type="checkbox"/> | Contractor or Subcontractor is a public entity.   |   |
| <input type="checkbox"/> | <input type="checkbox"/> | Contractor or Subcontractor participates in a contract awarded under Howard County Code Secs. 4.110 (Sole Source), 4.111 (Emergency), or 4.112 (Expedited).   |   |
| <input type="checkbox"/> | <input type="checkbox"/> | Contractor or Subcontractor is a regulated public utility.  |   |
| <input type="checkbox"/> | <input type="checkbox"/> | Contract was awarded under a cooperative procurement with another government or organization of governments.  |   |

**Check here  if none of the above statements are applicable to your company or to the Subcontractor, continue to Section 2.**

**Section 2: Certifications**

- If you checked any exemptions in Section 1, skip this section and continue to Section 3.
- If you did not check any exemptions in Section 1, check each box in Section 2 that applies to your company, then complete Section 3 below.

I do hereby certify that I have read and understand the provisions of Section 4.122A of the Howard County Code, that I am an authorized representative of the Contractor named below, and that:

- As a “covered employer,” the Contractor and all Subcontractors will comply with the County’s Wage Rate Requirements for Service Contracts (Howard County Code Sec. 4.122A) and will pay all employees not exempt under the wage requirements, and who perform direct measurable work for the County, the applicable wage requirements at the time the work is performed. The Contractor will keep the records necessary to show compliance and will submit such records to the Purchasing Agent on request of the Purchasing Agent; and will publicize the requirements of this law to any employees who may be covered by the law. The Contractor’s proposed pricing is sufficient to meet the current living wage rate requirements during the initial term of the agreement and any increases applicable to subsequent renewals.
- If health insurance is provided to employees**, the per employee hourly cost of the premium for health insurance to an employee who provides services to the County that appears in the bid or proposal is correct.

**Section 3: Contact Information** Provide your contact information in the space below, then sign and date this form and submit it with your bid.

Contractor Name \_\_\_\_\_ Vendor Federal ID Number \_\_\_\_\_

Address \_\_\_\_\_ Phone Number \_\_\_\_\_

\_\_\_\_\_ Email Address \_\_\_\_\_

Authorized Signature \_\_\_\_\_ Date \_\_\_\_\_

Print Name of Signatory \_\_\_\_\_ Title of Signatory \_\_\_\_\_

|                                      |   |                |                                     |
|--------------------------------------|---|----------------|-------------------------------------|
| <b>Office of Purchasing Use Only</b> | Contract Title: OAKLAND WATER TANK CLEANING AND COATING |                | <b>Buyer’s Initials:</b><br><br>ACA |
|                                      | Contract No:  | Renewal No.    |                                     |
|                                      | Capital Project No:                                     | Contract Term: |                                     |

# **APPENDICES**

# APPENDIX A

## OAKLAND WATER TANK FLAT SURFACE AREA SQUARE FOOTAGE ESTIMATE

### Exterior Tank Surface

|                        |               |
|------------------------|---------------|
| Surface Area of Bowl   | 12,700        |
| Surface Area of Legs   | 20,800        |
| Surface Area of Column | <u>8,000</u>  |
| <b>Total</b>           | <b>50,500</b> |

### Interior Wet Surface

|   |               |
|---|---------------|
| Surface Area of Bowl + Inside Wet Riser | <u>25,000</u> |
| <b>Total</b>                            | <b>25,000</b> |

### Interior Dry Surface

|   |                  |
|---|------------------|
| Surface Area of Dry Column  | 8,000 Clean Only |
| Surface Area of Wet Riser,<br>Access Tube, Landings, Ladder, etc. | <u>6,000</u>     |
| <b>Total</b>  | <b>14,000</b>    |

## APPENDIX B

### OAKLAND WATER TANK

Address: 8700 Old Annapolis Road

Size: 1,500,000 gallons

Year Built: 1984

Overflow Elevation: 630'

Base Elevation: 521'

Overall Height: 124'

Bowl Diameter: 100'

Bowl Height: 55'

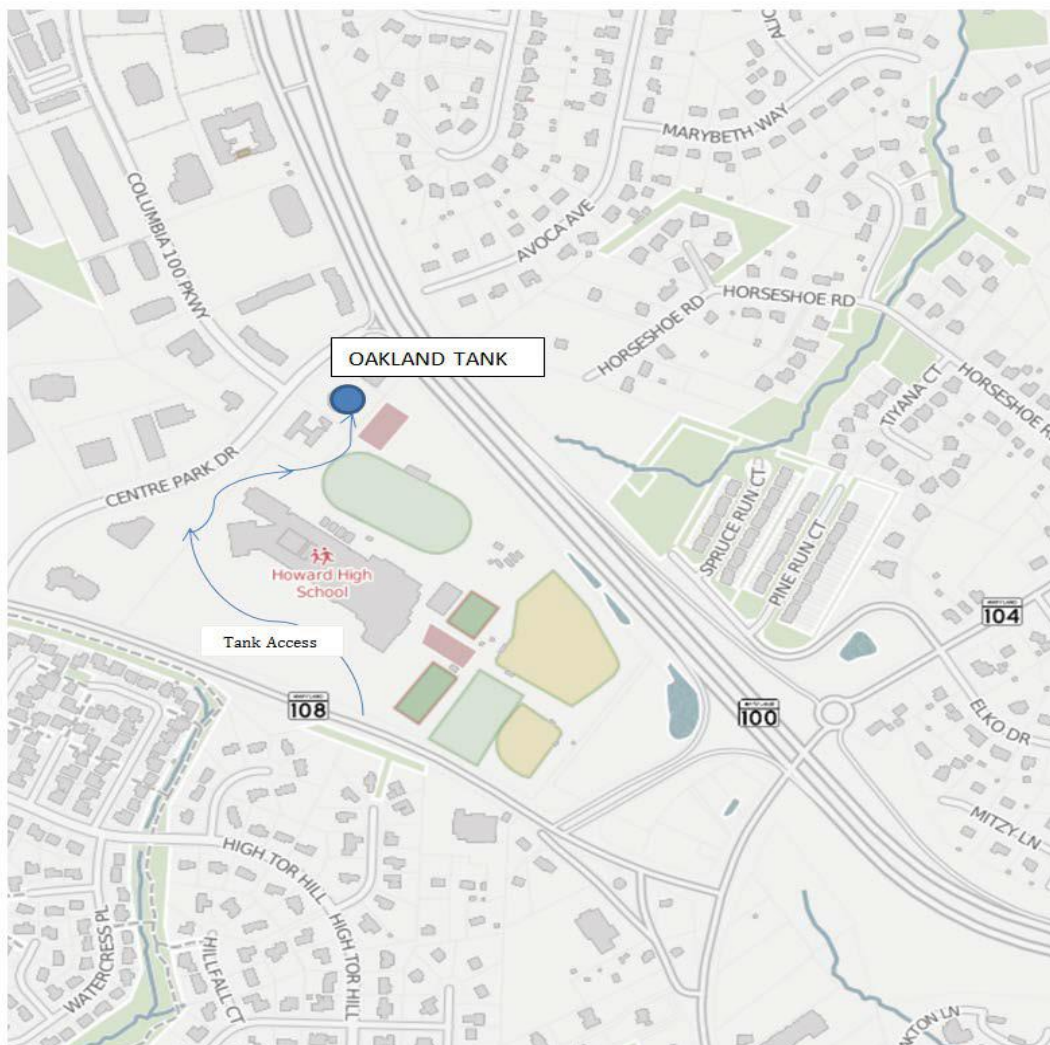

# APPENDIX C

## OAKLAND WATER TANK

- DIVING BOARD BLUE 44BL
- ▨ REFLECTION POOL 49BL

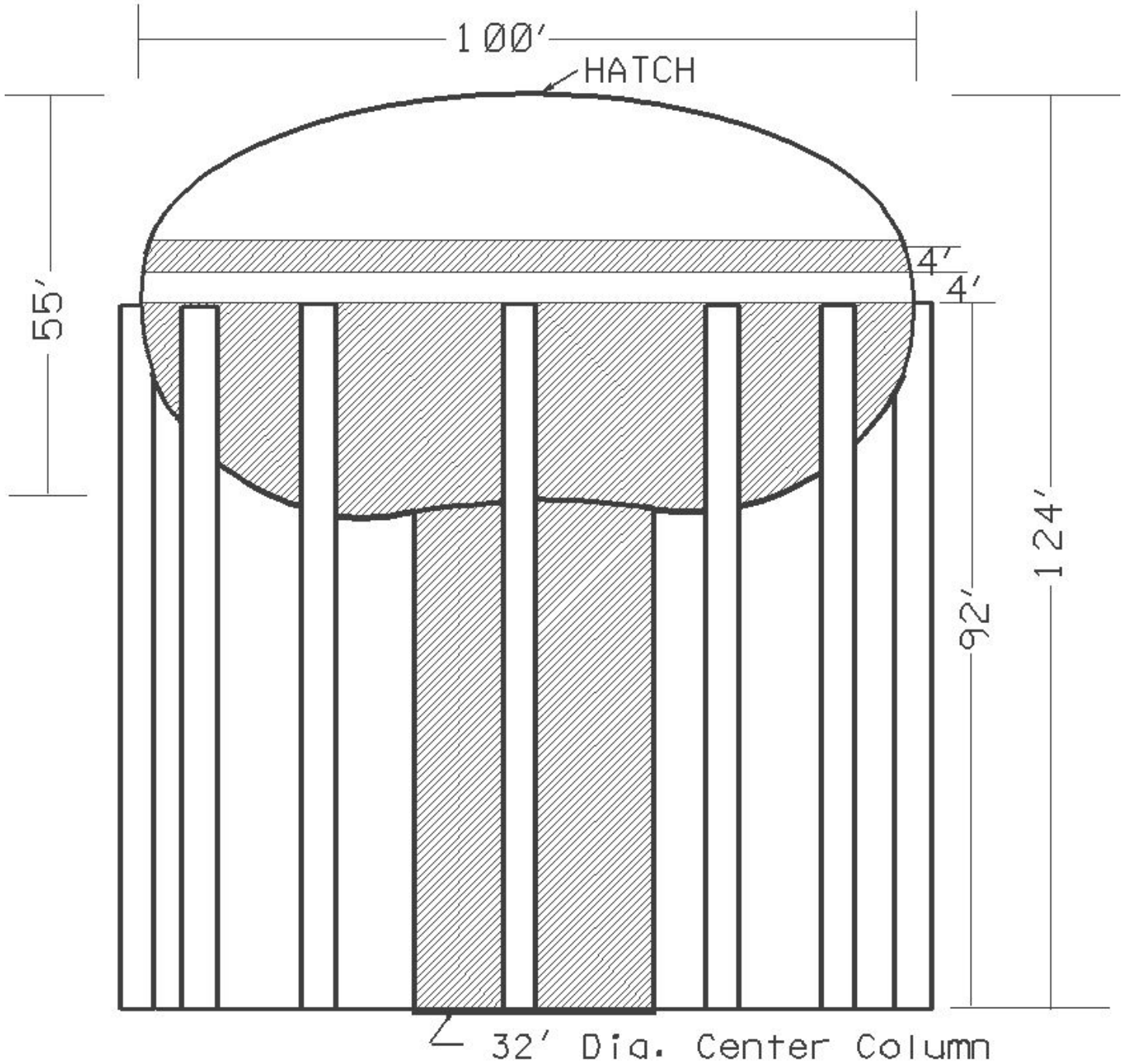

# APPENDIX D

## OAKLAND WATER TANK



# APPENDIX E

## OAKLAND WATER TANK DRIP EDGE

