

Chapter 10 –Electronic Pollbook

Introduction to the Electronic Pollbook	10.2
Unpacking the Electronic Pollbooks	10.3
Verifying the Electronic Pollbooks	10.6
Opening the Polls	10.10
Networking the Electronic Pollbooks	10.12
Networking Two Electronic Pollbooks	10.13
Networking Three or More Electronic Pollbooks to the Hub	10.15
Checking Synchronization	10.17
Entering and Clearing Data in the Pollbook	10.18
Finding Voters in the Electronic Pollbook	10.19
Finding Voters in the State Roster	10.22
Finding Voters by Street Address	10.23
Voter Not Found in the Electronic Pollbook	10.24
Voter is Registered in Another Precinct	10.25
Find a Voter’s Correct Polling Place	10.25
Checking in Voters	10.27
Issuing a Provisional Ballot	10.33
Special Situations	10.37
1. Voter Moved	10.37
2. Voter Claims a Different Party Affiliation or Whose Party Does Not Have a Ballot (Primary Election Only)	10.38
3. Voter’s Status is “Pend1”, “Pend2”, “ABS Issued”, or “Voted Early”	10.38
4. Inactive Status Voters (“ID Required” box is blank)	10.41
5. “Issued” Box is “Reg Issued” or “PROV”	10.42
6. ID Require – Show ID (Active or Inactive)	10.43
Standards for Acceptable Forms of ID	10.45
Standards for Unacceptable Forms of ID	10.46
Reprinting a Voter Authority Card	10.46
Resetting the Judge’s Name	10.47
Ending the Election	10.50
Packing the Electronic Pollbooks and Printers	10.54

Introduction to the Electronic Pollbook

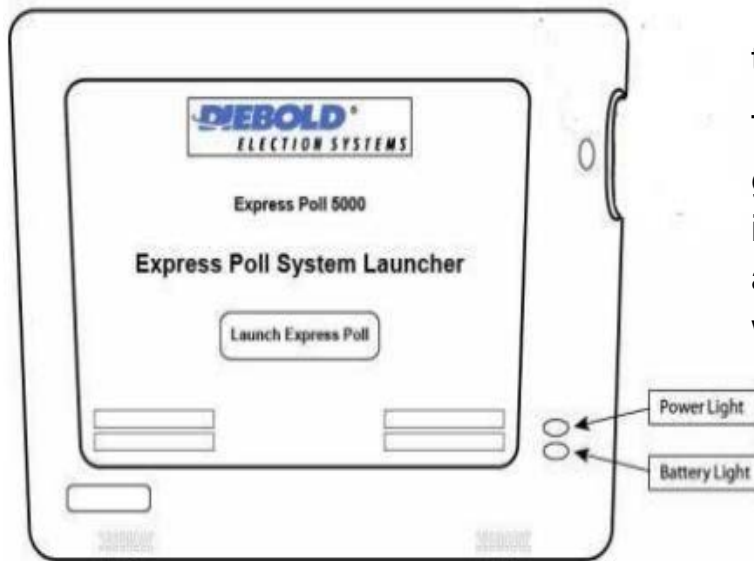

The **Power Light** is green when the unit is in use.

The **Battery Light** will flash green when the unit is plugged into an electrical power source and is charging. The light is off when there is no electrical power.

The **Compact Flash (CF) Card Slot** contains a compact flash card, a device used in the electronic pollbook for storing election information and a list of eligible voters. The protective cover for the Compact Flash Card Slot is to remain closed and sealed during an election.

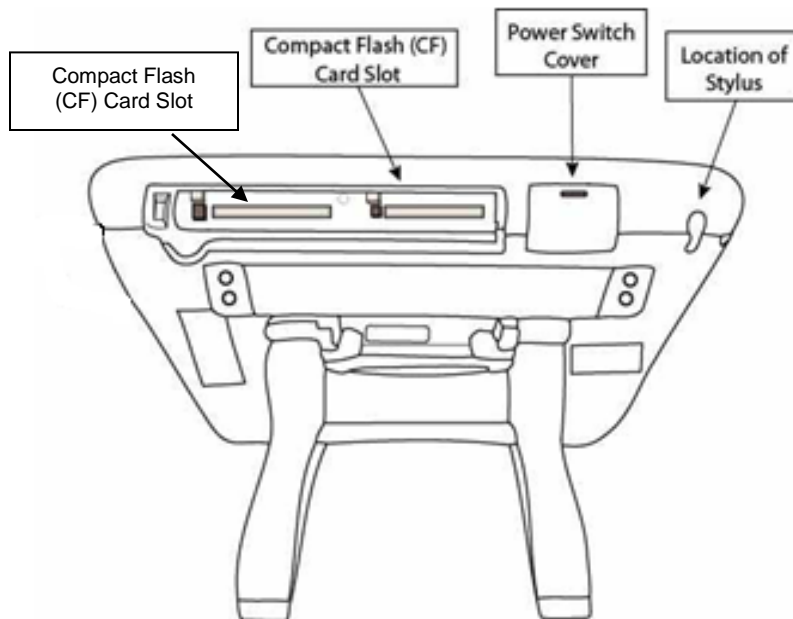

The **Power Switch Cover** can be opened to access the on/off power switch.

The **Stylus** is the pen-shaped instrument with a hard point stored in the top of the unit to be used to navigate the electronic pollbook. You use the stylus to “tap” commands on the screen.

Unpacking the Electronic Pollbooks

1. Verify the outer lock number on each case matches the number in column 1 of the *Electronic Pollbook Integrity Report*.



Pollbook cases packed in grey tote(s)



Electronic Pollbook Integrity Report
2018 Gubernatorial Primary Election

County: Howard State of Maryland
Dist/Pct: 01-08, BLKBRIDGE ELEMENTARY SCHOOL-CHESTERLA Date: 5/26/2018
Combined District/Precinct(s): 01-17

JUDGES MUST: Complete ALL Grey Areas

1. Opening: Print and sign the opening Ballot Counts Report and Voter Counts Report from each pollbook and attach them to this form before polls open.
2. Complete the "Opening" section.
3. During: Verify and record information if you have to remove the inner seal during the day.
4. Closing: Print and sign the Ballot Counts Report and Voter Counts Report from each pollbook and attach them to this form.
5. Complete the "Closing" section.
6. Have Chief Judges sign this form AFTER the polls close.

Pollbook ID Number	OPENING				DURING		CLOSING		
	Outer Lock # (on outside of storage case)	State Asset Tag # (on back of pollbook)	Red Seal # (on top lid of pollbook)	Verify inner seal was intact when polls opened	If inner red seal was removed during day please record reason Here. Use page back, if necessary	New Red Seal #	3 CR Cards removed from pollbook	Reattached Original Lock # Applied to storage case at close	
	VERIFY	VERIFY	VERIFY	DEM	REP	RECORD	RECORD	VERIFY	
5181	✓	0050239	✓					YES	5181
5210	✓	0048753	✓					YES	5210
3	✓	0050054	✓					YES	5199
4	✓	0037207	✓					YES	5386

To the best of our knowledge the information on this report is true and correct. The Electronic Pollbook CF Cards were removed at the close of the polls and packed in clear zipper bag for delivery to HCBQE by Rover/Clower.

REPUBLICAN CHIEF JUDGE _____ 2 DEMOCRATIC CHIEF JUDGE _____

2. Remove the outer lock using the blue key attached to the blue lanyard. Reattach lock to case when pollbook has been removed.
3. Open the two latches.
4. Remove the electronic pollbook and power cord from the case.

⚠ Do not grab the electronic pollbook by its legs! Use the elastic strap on the electronic pollbook.



- Verify the State Asset Tag number on the back of each electronic pollbook matches the numbers in column 2 of the *Electronic Pollbook Integrity Report*.

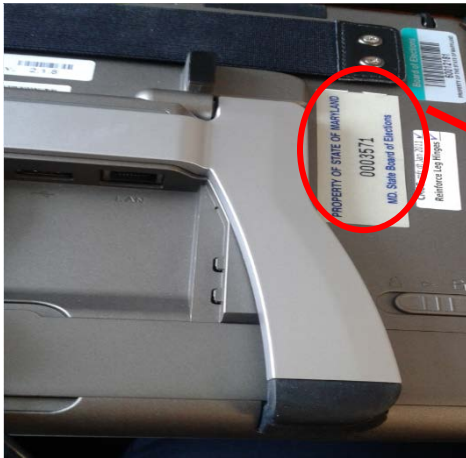

State of Maryland
Date: 6/26/2018

Electronic Pollbook Integrity Report
2018 Gubernatorial Primary Election

County: Howard
Dist/Prec: 01-08 ELKBRIDGE ELEMENTARY SCHOOL-CAFETERIA
Combined District/Precinct(s): 01-17

JUDGES MUST: Complete ALL Grey Areas

- Opening: Print and sign the opening Ballot Counts Report and Voter Counts Report from each pollbook and attach them to this form before polls open.
- Complete the "Opening" section.
- During: Verify and record information if you have to remove the inner seal during the day.
- Closing: Print and sign the Ballot Counts Report and Voter Counts Report from each pollbook and attach them to this form.
- Complete the "Closing" section.
- Have Chief Judges sign this form AFTER the polls close.

Pollbook ID Number	OPENING				DURING		CLOSING		
	Outer Lock # (on back of case)	State Asset Tag # (on back of pollbook)	Red Seal # (on top lid of pollbook)	Verify inner seal was intact when polls opened (initial)	If inner red seal was removed during day please record reason here. Use page back if necessary.	New Red Seal #	2 CF Cards removed from pollbook	Reattached Original Lock # (applied to storage case at closing)	
	VERIFY	VERIFY	VERIFY	DEM	REP	RECORD	RECORD	VERIFY	RECORD
1	5181	0050239						YES	5181
2	5210	0049753						YES	5210
3	5199	0050054						YES	5199
4	5366	0037207						YES	5366

To the best of our knowledge the information on this report is true and correct. The Electronic Pollbook CF Cards were removed at the close of the polls and packed in clear zipper bag for delivery to HCBOE by Rover/Closer.

REPUBLICAN CHIEF JUDGE _____ 2 DEMOCRATIC CHIEF JUDGE _____

Revised 12/1/17

- Verify the inner seal number on the top of each electronic pollbook is not broken and the number matches the numbers in column 3 of the *Electronic Pollbook Integrity Report*.



State of Maryland
Date: 6/26/2018

Electronic Pollbook Integrity Report
2018 Gubernatorial Primary Election

County: Howard
Dist/Prec: 01-08 ELKBRIDGE ELEMENTARY SCHOOL-CAFETERIA
Combined District/Precinct(s): 01-17

JUDGES MUST: Complete ALL Grey Areas

- Opening: Print and sign the opening Ballot Counts Report and Voter Counts Report from each pollbook and attach them to this form before polls open.
- Complete the "Opening" section.
- During: Verify and record information if you have to remove the inner seal during the day.
- Closing: Print and sign the Ballot Counts Report and Voter Counts Report from each pollbook and attach them to this form.
- Complete the "Closing" section.
- Have Chief Judges sign this form AFTER the polls close.

Pollbook ID Number	OPENING				DURING		CLOSING		
	Outer Lock # (on outside of storage case)	State Asset Tag # (on back of pollbook)	Red Seal # (on top lid of pollbook)	Verify inner seal was intact when polls opened (initial)	If inner red seal was removed during day please record reason here. Use page back if necessary.	New Red Seal #	2 CF Cards removed from pollbook	Reattached Original Lock # (applied to storage case at closing)	
	VERIFY	VERIFY	VERIFY	DEM	REP	RECORD	RECORD	VERIFY	RECORD
1	5181							YES	5181
2	5210	0049753						YES	5210
3	5199	0050054						YES	5199
4	5366	0037207						YES	5366

To the best of our knowledge the information on this report is true and correct. The Electronic Pollbook CF Cards were removed at the close of the polls and packed in clear zipper bag for delivery to HCBOE by Rover/Closer.

REPUBLICAN CHIEF JUDGE _____ 2 DEMOCRATIC CHIEF JUDGE _____

Revised 12/1/17

- Verify the Power Switch on the top is turned OFF.



8. Insert the power cord (marked with yellow tape) into the first connection slot marked with PWR and the other end into a power source. Do NOT turn on the power switch yet!



9. Take the printer's USB cable from the printer case and plug the larger end into either of the two USB ports located on the back of the electronic pollbook.

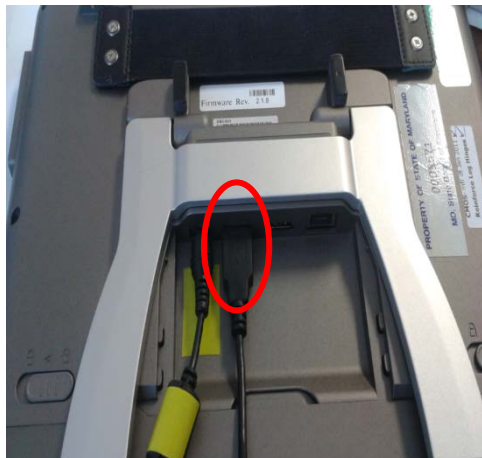

10. Plug one end of the printer's power cord (marked with blue tape) into the printer and the other end into a power source.

! The printer end of the power cord is bent 90 degrees (elbow shaped). DO NOT connect an electronic pollbook power cord to the printer. It will cause severe damage to the printer.

11. Plug the smaller end of the USB cable into the printer.



12. Repeat steps 2 through 11 for all electronic pollbooks.



There should be one printer for each electronic pollbook. If there are any printers missing, contact the local board of elections.

Verifying the Electronic Pollbooks

1. Turn the power switch to ON. DO NOT NETWORK THE POLLBOOKS YET.



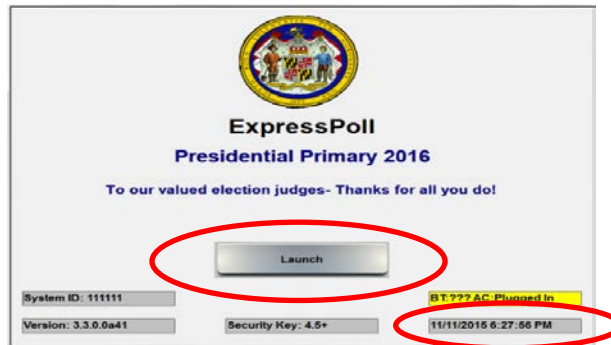

2. When the electronic pollbook switch is ON, the “Launch” screen will appear.
 - Verify the date and time is correct. If the date or time is incorrect, alert a chief judge who will seek technical support.

- If the date and time is correct, tap the “Launch” button with the stylus.

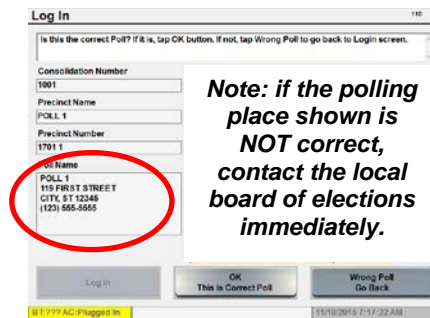

3. Verify the poll name on the left side.  At the pre-election night meeting pollbooks would be powered off at this point. During pre-election morning set up, follow above steps 1 – 3 starting on page 10.6 and continue to when pollbooks are ready to check-in voters.



 If the polling place shown is not correct, alert a chief judge who will contact the local board of elections immediately.

4. During election morning set up tap the “OK This is Correct Poll” button at the bottom of the screen.

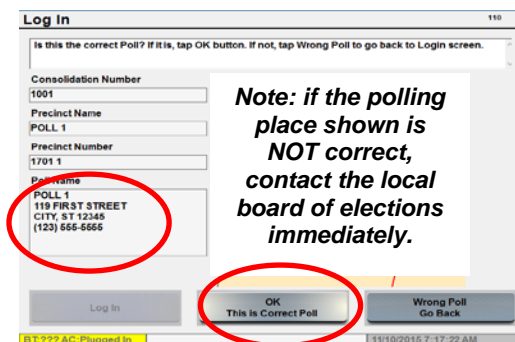

5. Select “Yes” or “No” when prompted to check the clock accuracy in bottom right corner.

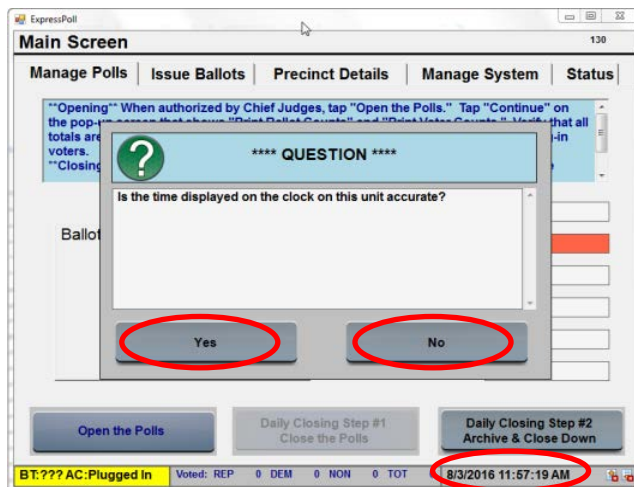

- If “No” is selected, go to step 6.
 - If “Yes” is selected, go to step 7.
6. Make the date and/or time adjustments by tapping “+” or “-”. Select “Set Clock Time” to make changes.

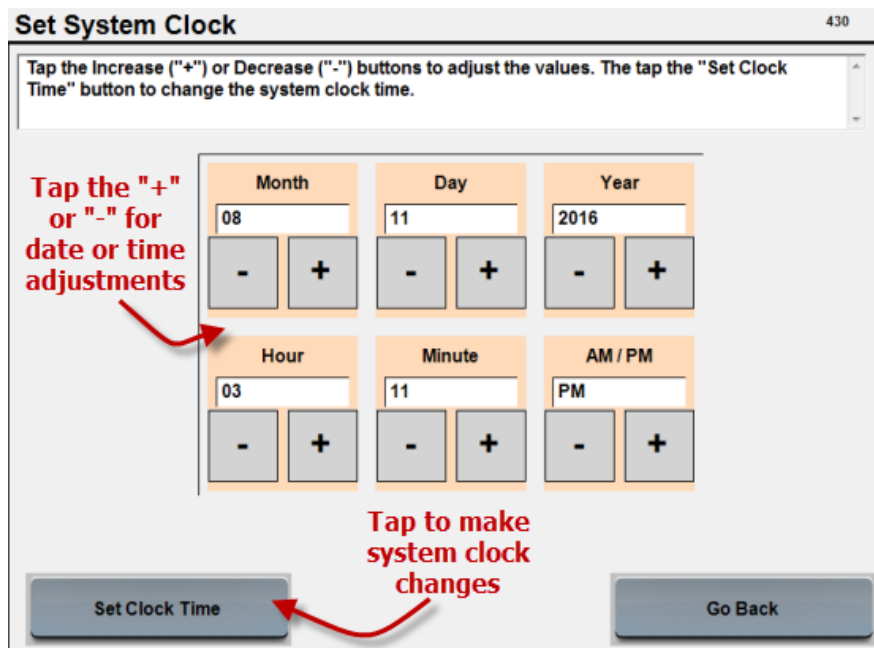

7. The “Main Screen” will appear with the “Manage Polls” tab at the top of the screen. The Poll Status will be “Closed.”



Almost everything you will need to know about using the electronic pollbook is in the onscreen instructions. Please read them!

Main Screen 130

Manage Polls | Issue Ballots | Precinct Details | Manage System | Status

****Opening**** When authorized by Chief Judges, tap "Open the Polls." Tap "Continue" on the pop-up screen that shows "Print Ballot Counts" and "Print Voter Counts." Verify that all totals are 0. Tap the "Issue Ballots" tab then "Search Voter Roster" to begin checking-in voters.

****Closing**** When authorized by Chief Judges, tap "Step #1-Close the Polls." Print the

Statistics

Ballots | Voters

Standard Ballots 0

Provisional Ballots 0

Consolidation Number 02001001

Poll Status **CLOSED**

Poll Opening Time 10:00AM

Poll Closing Time 8:00PM

of Registered Voters 1564

Bulk Update Date

Open the Polls | Daily Closing Step #1 Close the Polls | Daily Closing Step #2 Archive & Close Down

BT:??? AC:Plugged In | Voted: TOT 0 | 1/23/2018 10:15:27 AM

8. Tap the "Ballots" and "Voters" tabs under the "Statistics" to verify that all the numbers are zero. Be sure to check both tabs under "Statistics" for zeroes before networking the electronic pollbooks.

Main Screen 130

Manage Polls | Issue Ballots | Precinct Details | Manage System | Status

****Opening**** When authorized by Chief Judges, tap "Open the Polls." Tap "Continue" on the pop-up screen that shows "Print Ballot Counts" and "Print Voter Counts." Verify that all totals are 0. Tap the "Issue Ballots" tab then "Search Voter Roster" to begin checking-in voters.

****Closing**** When authorized by Chief Judges, tap "Step #1-Close the Polls." Print the

Statistics

Ballots | Voters

Standard Ballots 0

Provisional Ballots 0

Consolidation Number 02001001

Poll Status **CLOSED**

Poll Opening Time 10:00AM

Poll Closing Time 8:00PM

of Registered Voters 1564

Bulk Update Date

Open the Polls | Daily Closing Step #1 Close the Polls | Daily Closing Step #2 Archive & Close Down

BT:??? AC:Plugged In | Voted: TOT 0 | 1/23/2018 10:15:27 AM



Alert a chief judge immediately if any of these numbers are not zero. Do not network the electronic pollbooks if any number is not zero.

9. Verify that the totals at the bottom of the screen are zero.

For the primary election:



For the general election:



Alert a chief judge immediately if any of these numbers are not zero. Do not network the electronic pollbooks if any number is not zero.

10. Repeat steps 1 through 9 for all electronic pollbooks.

Opening the Polls

Do not check-in voters before 7:00 a.m.

Steps 1 through 4 can be performed on each electronic pollbook before 7:00 a.m.

1. Tap the "Open the Polls" button

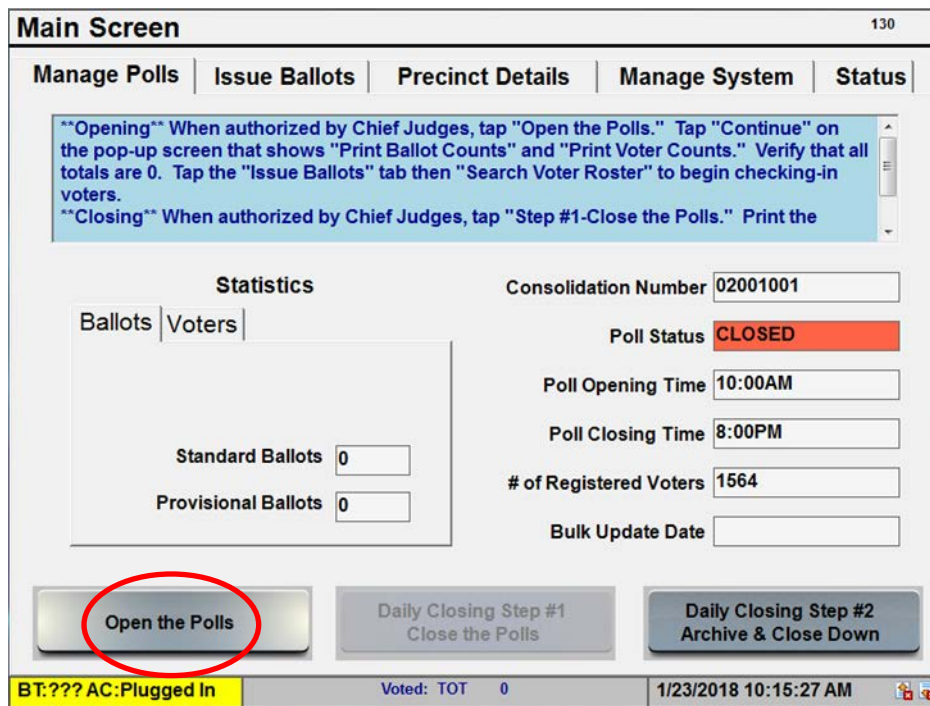

- Be sure the Print Ballot Counts and Print Voter Counts boxes have check marks in the pop-up menu.

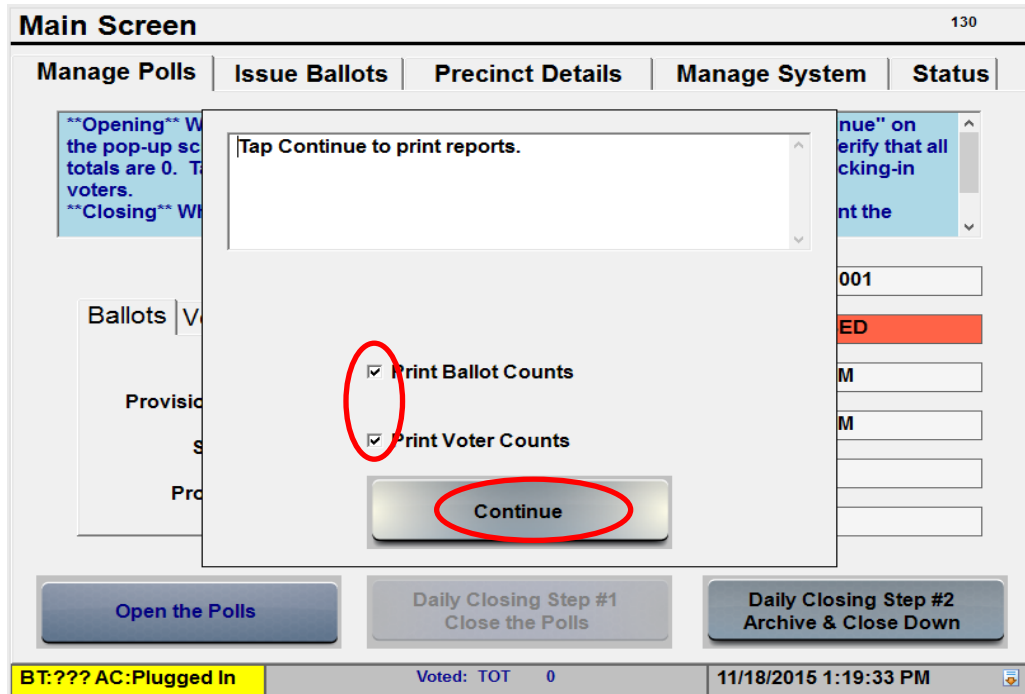

- Tap "Continue" to print the Ballot Counts and Voter Counts reports.
- Two reports will print.
- Verify all totals on the Consolidated Voter Counts Report and Consolidated Ballot Counts Report are zero. Alert a chief judge immediately if the totals are not zero.

Consolidated Voter Counts Report
 Consolidation: # 08EV01 EPB Number: 035979
 Poll Description: Charles County Board of Elections
 Report Date and Time: 11/17/2015 09:52:54

Party	Total	Reg	Provisional
REP	0	0	0
DEM	0	0	0
GRN	0	0	0
LIB	0	0	0
UNA	0	0	0
OTH	0	0	0
TOT	0	0	0

DEM Judge _____
 REP Judge _____

Consolidated Ballot Counts Report
 Consolidation: # 20005001 EPB Number: 999
 Poll Description: Mt Vernon Fire Dept
 Report Date: 04/01/2010 13:45:31

	TOT	DEM	REP	NON
Issued	0	0	0	0
Reiss	0	0	0	0
Canc	0	0	0	0
Net	0	0	0	0
Prov Issued	0	0	0	0
Prov Reiss	0	0	0	0
Prov Canc	0	0	0	0
Net Prov	0	0	0	0
Net Ballots	0	0	0	0

DEM Judge _____
 REP Judge _____

6. The “Poll Status” will change from red to green and display “OPENED.”

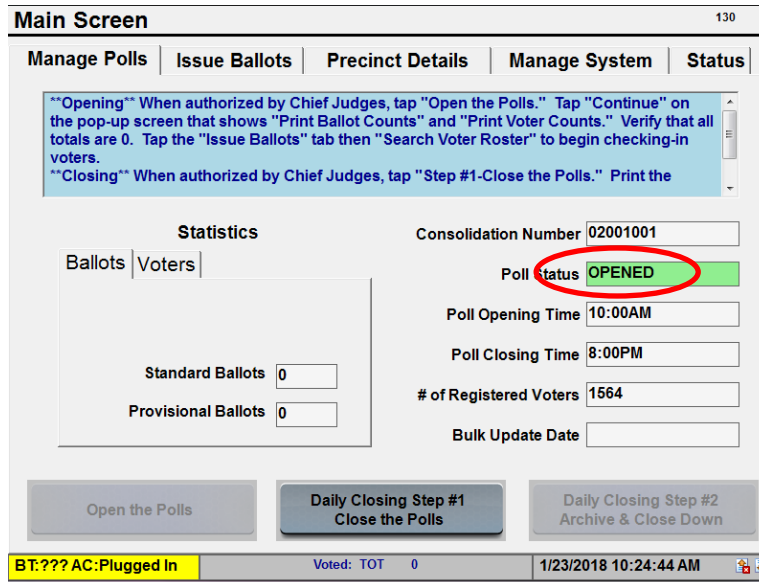

7. Repeat steps 1 through 6 for all electronic pollbooks.

Networking the Electronic Pollbooks



Do not network the electronic pollbooks until after:

- All electronic pollbooks have been turned on individually.
- The “Statistics” on the “Main Screen” are verified as zeroes for the “Ballots” and “Voter” tabs.
- After the *Consolidated Voter Counts Report* and *Consolidated Ballot Counts Report* are printed on each electronic pollbook.

A. The back of the electronic pollbook has four ports, from left to right:

1. Power connection
2. Two USB ports for the printer
3. LAN port that connects all the electronic pollbooks in the same polling place together

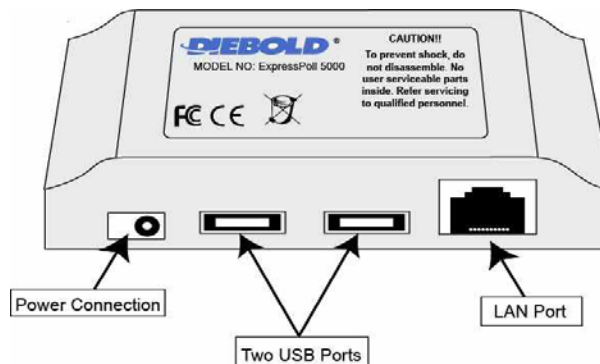

- B. All cable connectors are unique and fit only one way. Insert the USB plug with USB icon facing up. Insert LAN plug with locking tab facing up.



Networking Two Electronic Pollbooks

 For more than two electronic pollbooks, see the “Networking Three or More Electronic Pollbooks to the Hub” section of this chapter.

1. Turn both electronic pollbooks **OFF** before connecting the network cables.



2. Connect one end of the red crossover cable into the LAN port on the back of one electronic pollbook.



3. Connect the other end of the crossover cable into the LAN port on the back of the other electronic pollbook.



4. Turn an electronic pollbook ON one at a time until the “Launch” screen appears.



5. Proceed to the “Checking Synchronization” section of this chapter.

Networking Three or More Electronic Pollbooks to the Hub

 For two electronic pollbooks, see the “Networking Two Electronic Pollbooks” section of this chapter.

1. Turn all electronic pollbooks **OFF before** connecting the network cables.



2. The hub (or switch) connects more than two electronic pollbooks and allows them to synchronize data in a polling place. There are several models used and their appearances vary.



3. Connect the hub's power cord into the first socket in the back of the hub.



4. Insert the power cord plug into the power strip. The hub's power light indicator will turn on.
5. Connect one end of a hub cable into the LAN port of an electronic pollbook.



6. Connect the other end of the hub cable to any port in the hub.



7. Repeat steps 1 through 6 for each electronic pollbook.

8. Turn an electronic pollbook ON one at a time until the “Launch” screen appears.



9. Proceed to the “Checking Synchronization” section of this chapter.

Checking Synchronization

Check that the electronic pollbooks are synchronized with other electronic pollbooks in the polling place. This is indicated by a pair of icons in the lower right corner of the screen. If the electronic pollbooks are not synchronized, check that all connections between the electronic pollbooks and the hub are intact. If the electronic

pollbooks will not synchronize, alert a chief judge who will seek technical assistance.

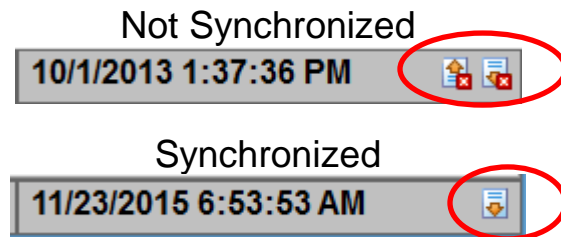

Throughout the day, periodically check the “Voted:” totals at the bottom of the screen against the other electronic pollbook(s) in the polling place. All totals should match.



If the electronic pollbooks are not synchronized, check that all connections between the electronic pollbooks and the hub are intact. If the electronic pollbooks will not synchronize, alert a chief judge who will seek technical assistance.

Entering and Clearing Data in the Pollbook

The electronic pollbook accepts only letters A-Z for name lookup. (No spaces, hyphens or apostrophes.) The voter’s name will print correctly (including apostrophes) on the voter authority card.

- Tap the “back space” key to delete one or more letters.
- Tap the “clear” key to delete an entire field.
- Tap the “Clear ALL” button to clear all search fields.

Finding Voters in the Electronic Pollbook



Check-in judges **may not ask for ID**, but may accept an ID **if offered** by a voter. Judges **must also ask** the voter to state his or her name, address, and month and day of birth.

1. Tap the “Issue Ballots” tab at the top of the screen.

Main Screen 130

Manage Polls | **Issue Ballots** | Precinct Details | Manage System | Status

****Opening**** When authorized by Chief Judges, tap "Open the Polls." Tap "Continue" on the pop-up screen that shows "Print Ballot Counts" and "Print Voter Counts." Verify that all totals are 0. Tap the "Issue Ballots" tab then "Search Voter Roster" to begin checking-in voters.

****Closing**** When authorized by Chief Judges, tap "Step #1-Close the Polls." Print the

Statistics

Ballots | Voters

Standard Ballots

Provisional Ballots

Consolidation Number

Poll Status **OPENED**

Poll Opening Time

Poll Closing Time

of Registered Voters

Bulk Update Date

Open the Polls | Daily Closing Step #1 Close the Polls | Daily Closing Step #2 Archive & Close Down

BT:??? AC:Plugged In | Voted: TOT 0 | 1/23/2018 10:24:44 AM

2. Tap the “Search Voter Roster” button on the bottom left of the “Issue Ballots” screen.

Main Screen 130

Manage Polls | **Issue Ballots** | Precinct Details | Manage System | Status

Use only letters A - Z for lookup. (No hyphens, spaces or apostrophes).

***** USE "4 & 3" for Faster Lookup! *****

- 1) Enter the FIRST 4 LETTERS of the LAST NAME.
- 2) Enter the FIRST 3 LETTERS of the FIRST NAME.
- 3) Confirm the voter's DATE OF BIRTH.

Tap the "Search Voter Roster" button to check in voters.

The "Find Polls" button is used to find a polling place based on the voter's street address.

Search Voter Roster | Find Polls

BT:??? AC:Online | Voted: DEM 0 REP 0 NON 0 TOT 0 | 10/29/2013 10:35:20 AM

Find Voters 205

Name	Address	County	DOB	Status	Issued	Party
Linc Abraham Quincy	Main St APT A Anytown 12345	Anne Arundel	03/01 /1802	Active	None	REP
Lincoln Abe Q	1/2 Main St Anytown 12345	Anne Arundel	03/23 /1994	Active	None	UNA
Lincoln Abraham Quincy	2 Main St Anytown 12345	Anne Arundel	02/02 /1836	Active	None	DEM
Lincoln Abraham Quincy	1 Main St Anytown 12345	Anne Arundel	01/01 /1830	Active	None	NON

7 voters found.

Find by Name | Find by Address | Find by ID

Last Name | L |

First Name | | Middle Init. | |

Zip Code | | Birth MMDD | |

1 2 3 4 5 6 7 8 9 0 .
Q W E R T Y U I O P -
A S D F G H J K L ' back space
Z X C V B N M space clear

Search Precinct/EV Count
Search State

Clear ALL

Return to Main

BT:???:AC:Online Voted: DEM 0 REP 0 NON 0 TOT 0 10/1/2013 2:50:22 PM

- Tap the “First Name” box before entering the first 3 letters of the voter’s first name. The list of names will get shorter as you add letters.

Find Voters 205

Name	Address	County	DOB	Status	Issued	Party
Linc Abraham Quincy	Main St APT A Anytown 12345	Anne Arundel	03/01 /1802	Active	None	REP

1 voters found.

Find by Name | Find by Address | Find by ID

Last Name | LINC |

First Name | ABR | Middle Init. | |

Zip Code | | Birth MMDD | 03/01 |

1 2 3 4 5 6 7 8 9 0 .
Q W E R T Y U I O P -
A S D F G H J K L ' back space
Z X C V B N M space clear

Search Precinct/EV Count
Search State (add mi)

Clear ALL

Return to Main

BT:???:AC:Online Voted: DEM 0 REP 0 NON 0 TOT 1 10/1/2013 1:26:06 PM



If you need to narrow down the search (a scroll bar appears on the right side indicating a long list), tap on the “Middle Init” box, and tap the first letter of the voter’s middle name. If the voter has no middle name, use the “space” key to enter a blank space in the “Middle Init” box.

You may also narrow the voter search by entering the voter’s zip code or month and day of birth. This can only be done after at least one letter has been entered for the voter’s last and first name fields.

6. Ask ***“What is your month and day of birth?”***

Name	Address	County	DOB	Status	Issued	Party
Linc Abraham Quincy	Main St APT A Anytown 12345	Anne Arundel	03/01 /1802	Active	None	REP

1 voters found.

Find by Name | Find by Address | Find by ID

Last Name: LINC
First Name: ABR | Middle Init.:
Zip Code: | Birth MMDD: 03/01

Search Precinct/EV Count
Search State (add mi)

Clear ALL
Return to Main

BT:?? AC:Online Voted: DEM 0 REP 0 NON 0 TOT 1 10/1/2013 1:26:06 PM

! Confirm the voter’s month and day of birth to be sure you see the correct voter. Be careful to not confuse father and son, mother and daughter, father and daughter, etc.

7. If you cannot find the voter’s name in the precinct roster:

- Enter the voter’s name without punctuation (apostrophes, hyphens, etc).
- Enter the voter’s date of birth (use the MMDD format). For example, August 2 would be entered as 0802.
- Check all possible variations of spelling for the name or ask the voter to spell his or her name.
- Search the State roster (see the “Finding Voters in the State Roster” section below).
- See the “Finding Voters by Street Address” section of this chapter.

Finding Voters in the State Roster

1. If you cannot find a voter’s name in the precinct roster and have verified the correct spelling, tap the “Search State” button to widen the search.

Find Voters 205

*** Voter NOT FOUND in Precinct ***.
 Search the state for this voter:
 1) Make sure that the "4 & 3" letters are entered correctly
 (first 4 letters of last name, first 3 letters of first name)
 3) Enter Date Of Birth
 2) Enter Middle Initial
 4) Tap the "Search State" button.
 If voter is still NOT FOUND, try "Find by Address"

Find by Name | Find by Address | Find by ID

Last Name: ZZZZ
 First Name: ZZZ Middle Init. X
 Zip Code: 20201 Birth MMDD: 09/19

Search Precinct/EV Count
 Search State
 Clear ALL
 Return to Main

BT:???:AC:Online Voted: DEM 0 REP 0 NON 0 TOT 0 10/1/2013 3:21:43 PM

2. If there are too many voters found in the State, enter more letters of the last and first names to narrow the search.

! When searching for a common name (Jane Smith, Mary Williams, James Johnson, etc.), the best way to narrow the search is to add the voter's middle initial, date of birth, and/or zip code.

! To use the middle initial to search for a voter with no middle name, you must use the "space" key to enter a blank space in the "Middle Init" box.

Finding Voters by Street Address

1. If you cannot find a voter's name after checking for various spellings, tap on the "Find by Address" tab and enter the voter's house number and street name.

Find Voters 205

Find a voter using a street address:
 1) Enter the Street name
 Note: If street name has a direction (N, S, E, W, NE, NW, SE, SW) the abbreviated direction MUST be included (with no period).
 Example: If voter lives on South Main Street, enter "S MAIN"
 2) Enter the House Number

Find by Name | Find by Address | Find by ID

House #
 Street Tap here to enter data Apt.
 Zip Code

Search Precinct/EV Count
 Search State (add mi)
 Clear ALL
 Return to Main

BT:???:AC:Plugged In Voted: TOT 2 1/14/2016 2:59:01 PM

Find Voters							205
Name	Address	County	DOB	Status	Issued	Party	
Harrison William Henry	9 Main St Anytown 12345	Anne Arundel	09/14 /1952	Active	ABS Issued	UNA	

1 voters found.

Find by Name | Find by Address | Find by ID

House # 9

Street MAIN Apt.

Zip Code

1 2 3 4 5 6 7 8 9 0 .

Q W E R T Y U I O P -

A S D F G H J K L ' back space

Z X C V B N M space clear

BT:?? AC:Plugged In Voted: TOT 0 10/1/2013 3:41:21 PM



The “Find by Address” lookup always searches the entire state.
 ***There will be a long pause after the first letter entered upon searching.

- If voter’s street name includes a directional, type “N” for “North,” “S” for “South,” etc. DO NOT put a period after the abbreviation.
- Select the voter’s name on the “Find Voters” screen to continue checking in the voter.

Voter Not Found in the Electronic Pollbook

If you cannot find the voter’s name in the electronic pollbook, alert a chief judge immediately. If necessary, a chief judge may call the Howard County Board of Elections at 410-313-5820 for a voter not found in pollbook searches for further confirmation. For a voter not found in the pollbook, the chief judge will explain to the voter his or her voting options.



If the voter cannot be found in the electronic pollbook, the voter may only be issued a provisional ballot.

1. If the voter is registered to vote and is at or chooses to go to the correct precinct for the voter's address, all contests will be counted.
2. If the voter is registered to vote and is not at and chooses not to go to the correct precinct for the voter's address, only the contests the voter is eligible to vote for will be counted.
3. If the voter is not registered to vote, no contests will be counted.

Voter is Registered in Another Precinct

The voter can choose to go to his or her correct precinct to vote or stay and vote a provisional ballot.

1. If the voter chooses to go to the correct precinct, every contest will be counted.
2. If the voter chooses to stay and vote a provisional ballot, only the contests the voter is eligible to vote for will be counted.

Use provisional code 1.

 The electronic pollbook will find a voter's assigned polling place based on the voter's registered address. See the "Find a Voter's Correct Polling Place" section in this chapter.

Find a Voter's Correct Polling Place

1. Tap "Find Polls" under the "Issue Ballots" tab on the Main Screen.

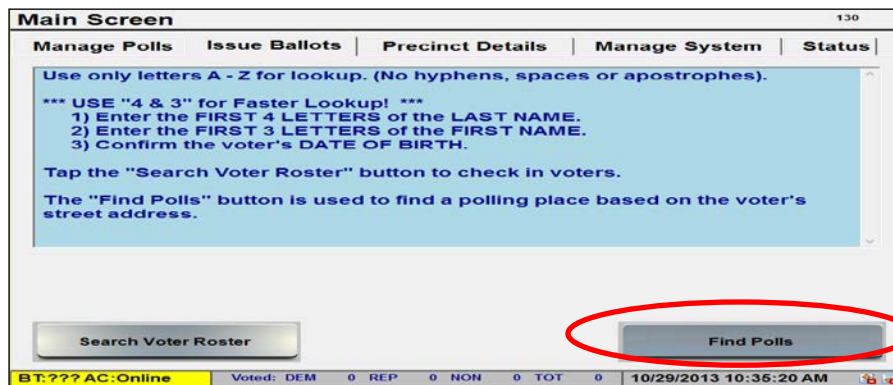

2. Enter the voter's current address.

Find the correct Polling Place for a Street Address 380

Find the polling place for a street address:
1) Enter the Street name
Note: If street name has a direction (N, S, E, W, NE, NW, SE, SW) the abbreviated direction **MUST** be included (with no period).
Example: If voter lives on South Main Street, enter "S MAIN"
2) Enter the House Number

House #

Street Apt.

Zip Code

1 2 3 4 5 6 7 8 9 0 .

Q W E R T Y U I O P -

A S D F G H J K L ' back space

Z X C V B N M space clear

Clear

Go Back to Find Voters

BT: ??? AC: Plugged In Voted: TOT 0 11/19/2015 1:36:34 PM

! If the street name includes a direction, the street name must be preceded by the directional abbreviation (N, S, E, W, etc.). Do not put periods after the abbreviation. It is not necessary to enter a street type (St, Rd, Ave, Ct, etc.) after the street name.

! For numbered streets, first try numbers (not spelled out.) Try "2ND" for 2nd Street or 2nd Avenue, "5TH" for 5th Ave. If the street is not found, try spelling out the street. For example, try: "FOURTH" for 4th Street or 4th Avenue, "W FIFTH" for West 5th Street.

3. All address ranges that match the search criteria will be displayed. Enter house number and zip code to narrow the search. Tap the row to display the polling place details.

Find the correct Polling Place for a Street Address 300

Street	House No.	Apt No.	Side	Precinct
Main Ave SW Glen Burnie 21061	2 to 320		B	002-007-1
Main St Prince Frederick 20678	00 to 1325		B	002-004-1
Main St Grantsville 21536	00 to 724		B	003-001-1
Main St Deer Park 21650	00 to 636		B	010-000-1

24 Streets Found

House #

Street Apt.

Zip Code

1 2 3 4 5 6 7 8 9 0 .

Q W E R T Y U I O P -

A S D F G H J K L ' back space

Z X C V B N M space clear

Clear

Go Back to Find Voters

BT: ??? AC: Plugged In Voted: TOT 0 11/19/2015 1:20:56 PM

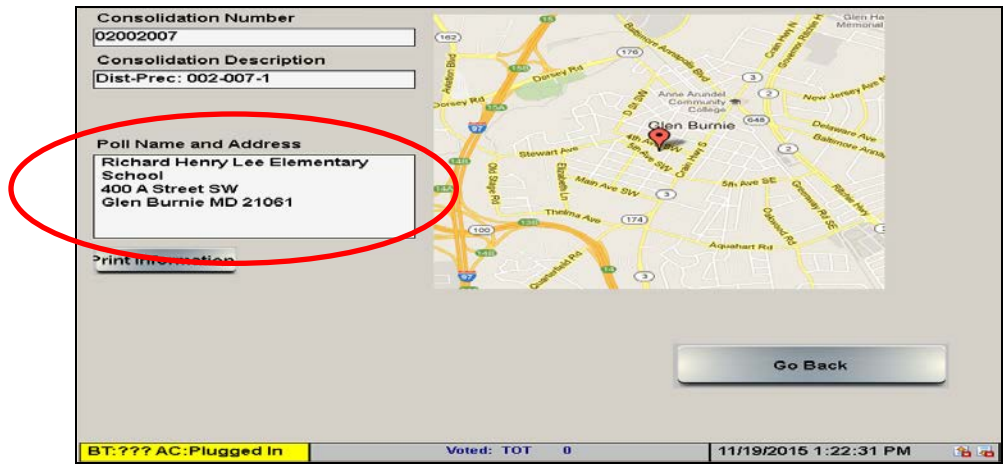

4. Tap the “Print Information” button for a paper print-out of the polling place name and address that can be given to the voter. The map will not print.

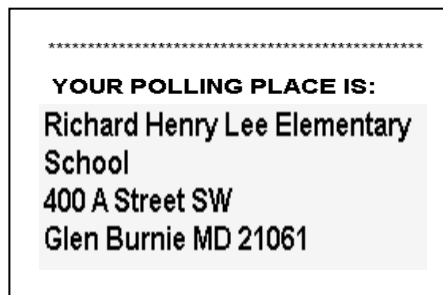

5. Tap “Go Back,” then tap “Go Back to Find Voters” to return to the Main Screen to continue checking in voters.

Checking in Voters

1. Once you have located the voter’s name, tap anywhere in that voter’s row on the screen to open the “Voter Record” screen. The “Voter Details” tab will be open.

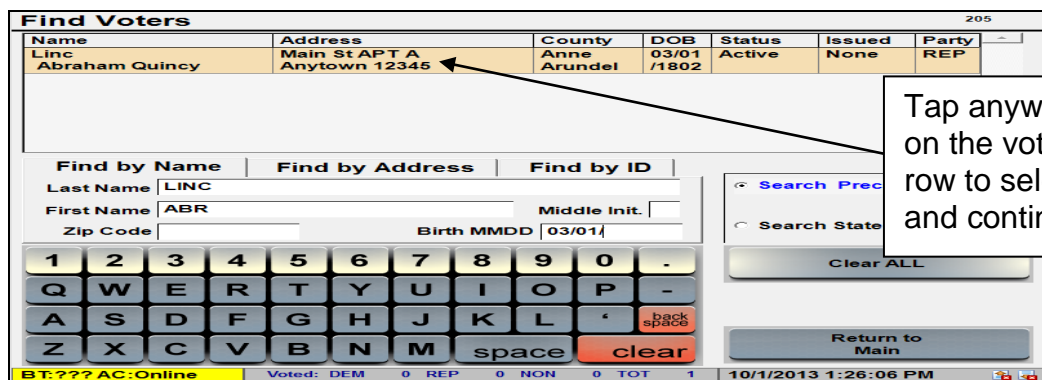

2. Ask “**What is your address?**” Compare the voter’s response with what is shown in “Voter Details.” If the voter’s response is the same as what is shown at the top of the screen, go to step 3.

 If the voter’s address is different than what is shown in the electronic pollbook, see item #1 of the “Special Situations” section of this chapter.

 If the voter’s address is marked “Confidential,” the voter’s address will not appear in the electronic pollbook. **Do not ask the voter to verify his or her address.** Continue the check-in process.

3. Review the information on the screen to confirm that you have the correct voter. If the information is correct and you are sure you have the correct voter, go to step 4 (Primary Election) or step 5 (General Election). Tap on the “Go Back” button if you have selected the wrong voter.

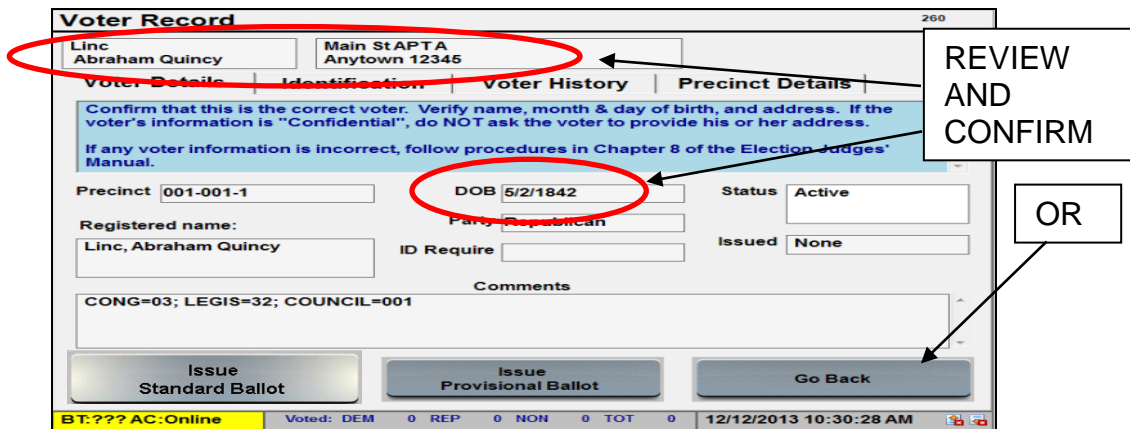

The screenshot shows the "Voter Record" screen with the following fields and annotations:

- Address:** Linc Abraham Quincy, Main St APT A, Anytown 12345. This entire section is circled in red.
- DOB:** 5/2/1842. This field is circled in red.
- Status:** Active
- Party:** Republican
- Registered name:** Linc, Abraham Quincy
- Comments:** CONG=03; LEGIS=32; COUNCIL=001
- Buttons:** Issue Standard Ballot, Issue Provisional Ballot, Go Back.

Annotations include a box labeled "REVIEW AND CONFIRM" with arrows pointing to the address and DOB fields, and a box labeled "OR" with an arrow pointing to the "Go Back" button.

4. **Primary election only:** Discreetly ask “**What is your party affiliation?**” If the voter’s response is the same as what is shown in the “Party” box, go to step 5.



If the voter claims a different party affiliation, wants to vote another party's ballot, or whose party does not have a ballot for this election, see item #2 of the "Special Situations" section of this chapter.

Voter Record 260

Linc: Abraham Quincy | Main St/APTA: Anytown 12345

Voter Details | Identification | Voter History | Precinct Details

Confirm that this is the correct voter. Check the voter's NAME, ADDRESS, and DOB. If the voter's information is "Confidential", Do NOT ask the voter to state his or her address.
If any voter information is incorrect, give the voter a Voter Update Form.

Precinct: 001-001-1 | DOB: 05/02/1842 | Status: Active
VRN: 3 | Party: **Republican** | Issued: None

Registered name: [] | ID Required: []

Comments: CONG=03; LEGIS=32; COUNCIL=001

Issue Standard Ballot | Issue Provisional Ballot | Go Back

BT:??? AC:Plugged In | Voted: TOT 0 | 1/23/2018 10:30:56 AM

5. Review the "Status" box in "Voter Details". If "Active" or "Inactive", proceed to Step #6.

Voter Record 260

Linc: Abraham Quincy | Main St/APTA: Anytown 12345

Voter Details | Identification | Voter History | Precinct Details

Confirm that this is the correct voter. Check the voter's NAME, ADDRESS, and DOB. If the voter's information is "Confidential", Do NOT ask the voter to state his or her address.
If any voter information is incorrect, give the voter a Voter Update Form.

Precinct: 001-001-1 | DOB: 05/02/1842 | Status: **Active**
VRN: 3 | Party: Republican | Issued: None

Registered name: [] | ID Required: []

Comments: CONG=03; LEGIS=32; COUNCIL=001

Issue Standard Ballot | Issue Provisional Ballot | Go Back

BT:??? AC:Plugged In | Voted: TOT 0 | 1/23/2018 10:30:56 AM



If the voter's status is "Pend1", "Pend2", "ABS Issued", or "Voted Early", see item #3 of the "Special Situations" section of this chapter.



If the voter's status is "Inactive" and the "ID Require" box is blank, see item #4 of the "Special Situations" section of this chapter.



If the voter's status is "Active" or "Inactive" and the "ID Require" box is "Show ID", see item #6 of the "Special Situations" section of this chapter.

- Review the "Issued" box in "Voter Details". If "None" or blank, **proceed to Step #7.**

Voter Record 260

Linc Abraham Quincy Main St APTA Anytown 12345

Voter Details | Identification | Voter History | Precinct Details

Confirm that this is the correct voter. Check the voter's NAME, ADDRESS, and DOB. If the voter's information is "Confidential", Do NOT ask the voter to state his or her address.
If any voter information is incorrect, give the voter a Voter Update Form.

Precinct: 001-001-1 DOB: 05/02/1842 Status: Active

VRN: 3

Registered name: Party: Republican **Issued: None**

ID Required: Comments: CONG=03; LEGIS=32; COUNCIL=001

Issue Standard Ballot Issue Provisional Ballot Go Back

BT:??? AC:Plugged In Voted: TOT 0 1/23/2018 10:30:56 AM



If the voter's "Issued" box is "Reg Issued" or "PROV", see item #5 of the "Special Situations" section of this chapter.

7. Review the “ID Required” box in “Voter Details”. If the “ID Required” box is blank, tap the “Issue Standard Ballot” button and **proceed to Step #8.**

The screenshot shows the "Voter Record" interface. At the top, there are two input fields: "Linc" with the value "Abraham Quincy" and "Main St APTA" with the value "Anytown 12345". Below these are four tabs: "Voter Details", "Identification", "Voter History", and "Precinct Details". A blue instruction box reads: "Confirm that this is the correct voter. Check the voter's NAME, ADDRESS, and DOB. If the voter's information is 'Confidential', Do NOT ask the voter to state his or her address. If any voter information is incorrect, give the voter a Voter Update Form." Below this, there are several fields: "Precinct" (001-001-1), "DOB" (05/02/1842), "Status" (Active), "VRN" (3), "Registered name:" (empty), "Party" (Republican), and "Issued" (None). The "ID Required" field is empty and circled in red. Below the fields is a "Comments" section with the text "CONG=03; LEGIS=32; COUNCIL=001". At the bottom, there are three buttons: "Issue Standard Ballot" (circled in red), "Issue Provisional Ballot", and "Go Back". The footer shows "BT:??? AC:Plugged In", "Voted: TOT 0", and "1/23/2018 10:30:56 AM".



If the voter’s “Status” is “Active” or “Inactive” and the “ID Require” box is “Show ID”, see item #6 of the “Special Situations” section of this chapter.



The first time you attempt to issue a ballot, you will be prompted to enter your name. Type in the first initial of your first name and then your last name with no spaces. Tap “OK” to continue. You will not have to enter your name or initials to issue ballots again unless the judge’s name on the electronic pollbook is reset. See the “Reset Judge’s Name” section of this chapter for more information.

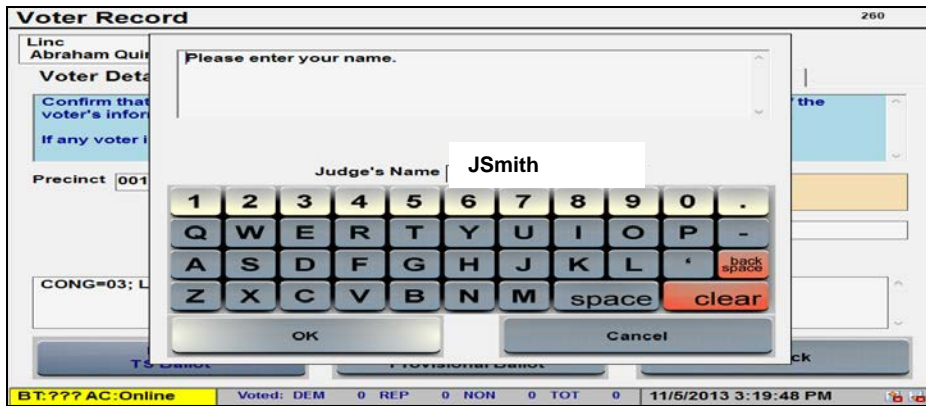

8. A voter authority card will print.
9. Ask the voter to verify the printed information and sign the voter authority card.

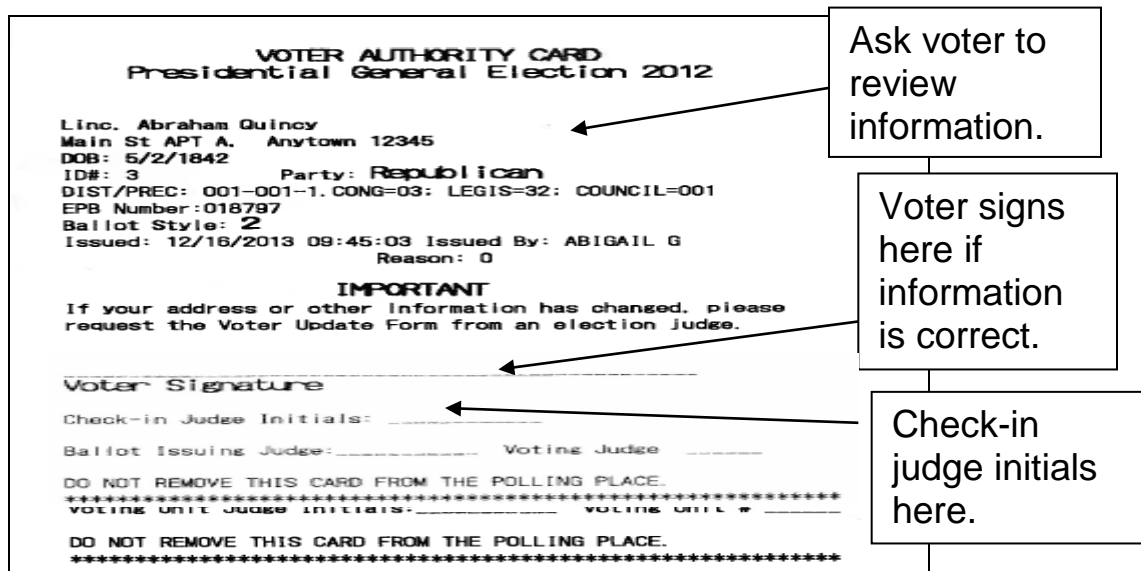

! If you checked-in the wrong voter and have already printed a voter authority card, alert a chief judge immediately.

10. The check-in judge initials the voter authority card.
11. Direct the voter to the ballot issuance table with voter authority card in their hand.
12. The voting judge at the ballot issuance table initials the voter authority card on the "Ballot Issuing Judge" line before giving the voter his or her paper ballot.

13. The voting judge will give the voter the paper ballot, privacy sleeve, and voter authority card and direct the voter to a voting booth. In the pollbook, this voter will now be marked as “Reg Issued” in the “Issued” column on the “Find Voters” screen.

Find Voters							205
Name	Address	County	DOB	Status	Issued	Party	
Linc Abraham Quincy	Main St APT A Anytown 12345	Anne Arundel	05/02 /1842	Active	REG Issued	REP	

1 voters found.

Find by Name | Find by Address | Find by ID

Last Name: LINC | First Name: | Middle Init: | Zip Code: | Birth MMDD: | Search Precinct/EV Count | Search State (add mi) | Clear ALL | Return to Main

BT:??? AC:Plugged In | Voted: TOT 2 | 11/19/2015 3:25:30 PM

 The “Voted:” counts on the status bar will increase by one for each voter who is issued a ballot. Counts shown are the number of voters, not ballots. A “re-issued” ballot will not increase the count. Party counts are based on the ballot issued party.

Issuing a Provisional Ballot

In some situations, the electronic pollbook automatically prevents a voter from being issued a regular ballot (i.e., not provisional) and allows only a provisional ballot to be issued. Examples include “pending” status voters and voters not in their registered precinct.

There are also situations where the electronic pollbook will allow a voter to be issued a regular ballot, but the voter should be issued a provisional ballot instead. Examples include “Active (or Inactive) - show ID” voters or voters who are challenged by a poll watcher

without acceptable identification, extended hours voters, and primary voters claiming a different party affiliation than what is shown in the electronic pollbook.

UNDER CHIEF JUDGE SUPERVISION, once it has been determined that the voter should be issued a provisional ballot, the steps are:

1. Voter must be qualified as a provisional voter by a chief judge.
2. Verify the voter's information on the "Voter Details" tab in the "Voter Record" screen.
3. Tap "Issue Provisional Ballot" button.

The screenshot shows the 'Voter Record' interface for John Quincy Adams. The voter's name and address are displayed at the top. Below this, there are tabs for 'Voter Details', 'Identification', 'Voter History', and 'Precinct Details'. A blue highlighted message states: 'This voter is flagged as "Voted Early." If the voter wants to cast a ballot now, he or she must vote by provisional ballot. Enter "4" on the "Enter Provisional Reason" screen.' The voter's details include Precinct 001-001-1, DOB 3/16/1800, Status Voted Early, Registered name Adams, John Quincy, Party Democrat, and Issued None. A comments field contains 'CONG=03; LEGIS=32; COUNCIL=001'. At the bottom, there are two buttons: 'Issue Provisional Ballot' (circled in red) and 'Go Back'. The footer shows 'BT:??? AC:Online', voting counts for DEM, REP, NON, and TOT, and the date/time 12/12/2013 12:13:03 PM.

4. The "Select Ballot" screen will appear. Tap on "Select Ballot Reason" to access a drop-down menu of provisional ballot reason codes. The "Select Paper Ballot" button will become available after a provisional ballot reason code is selected.



The voter's current information is highlighted in blue.



Carefully select the appropriate provisional ballot reason code. It is very important to enter the correct reason code.

Select Ballot 310

Verify voter's Precinct. Select the appropriate reason code from the drop down. Then tap "Issue Provisional".

Verify Voter's PRECINCT 001-001-1	Select PARTY Non-Partisan Democrat Republican
--------------------------------------	--

Voter Name Precinct

Ballot Style =Panel Ball

Select Ballot Reason

BT:??? AC:Plugged In Voted: TOT 3 1/14/2016 3:14:49 PM



Tapping the "Cancel No Ballot Issued" button will return you to the "Find Voters" screen.

5. Tap the "Select Paper Ballot" button.

Select Ballot 310

Verify voter's Precinct. Select the appropriate reason code from the drop down. Then tap "Issue Provisional".

Verify Voter's PRECINCT 001-001-1	Select PARTY Non-Partisan Democrat Republican
--------------------------------------	--

Voter Name Precinct

Ballot Style =Panel Ball

Select Ballot Reason

BT:??? AC:Plugged In Voted: TOT 3 1/14/2016 3:17:16 PM

6. The voter authority card will print. Initial it and have the voter review and sign it. Chief judge will escort the voter to the provisional voting area.
7. The electronic pollbook will return to the “Find Voters” screen.

 The reason code will print on the voter authority card. The provisional judge needs to enter the same reason code on the voter’s provisional ballot application.

VOTER AUTHORITY CARD
 Presidential General Training 2016

 PROVISIONAL BALLOT
 Reason Code: 9

SMITH, JOHN
 417 E Baltimore St. Baltimore 21202
 DOB: 10/14/1980
 ID#: 3806f23b-0ff9-4a8e-80ef-b83cf15e40e6
 Registered Party: Democrat
 Assigned Dist/Prec: 004-001.CONG=07: LEGIS=46: COUNCIL=011

EPB Number: 054955

Ballot Issued Dist/Prec: 001-001.CONG=07: LEGIS=44B: COUNCIL=001

DO NOT ISSUE REGULAR BALLOT
 Provisional Ballot Style: 2

Issued: 08/31/2016 14:48:16 Issued By: JUDGE NAME
 Issuing Consolidation: 04EV01

Please sign in the space below.

 Voter Signature

Check-in Judge Initials: _____
 Provisional Judge Initials: _____

DO NOT REMOVE THIS CARD FROM THE POLLING PLACE

8. A chief judge must escort the provisional voter from the check-in table to the provisional judge. Local board of elections may also use an escort judge or another election judge delegated by the chief judge.
9. The voter will now be marked as “PROV” in the “Issued” column on the “Find Voters” screen.

Name	Address	County	DOB	Status	Issued	Party
Adams	10 Main St	Anne Arundel	10/20	Voted	PROV	OTH
John Quincy	Anytown 12345		/1922	Early		

1 voters found.

Find by Name | Find by Address | Find by ID

Last Name: ADAM
 First Name: JOHN Middle Init. [Q]
 Zip Code: Birth MMDD:

Search Precinct/EV Count
 Search State

Clear ALL

Return to Main

BT:??? AC:Online Voted: DEM 0 REP 1 NON 1 TOT 2 10/18/2013 11:46:31 AM

Special Situations

The electronic pollbook has been set up so that a check-in judge can follow procedures to issue either a regular (i.e., not provisional) ballot or a provisional ballot. In certain cases the electronic pollbook will allow only a provisional ballot to be issued to a voter. Wherever possible, instructions are provided in the top section of the screen.

1. Voter Moved

If the voter's current address is different than what is shown in the electronic pollbook, ask the voter **WHEN** he or she moved to the current address.

- If the voter moved **within 21 days of election day**, complete a *Voter Update Form*. If the voter completes and signs the *Voter Update Form*, issue the voter a regular ballot. If the voter refuses to complete and sign the *Voter Update Form*, issue the voter a provisional ballot. See the "Issuing a Provisional Ballot" section of this chapter.
- If the voter moved **more than 21 days before election day**, the voter must be issued a provisional ballot. The provisional ballot application will serve to update the

voter's information and **no *Voter Update Form* is needed.**



“21 Day” dates for the 2018 elections:

Primary Election – If the voter moved prior to June 5, 2018, the voter must be issued a provisional ballot.

General Election – If the voter moved prior to October 16, 2018, the voter must be issued a provisional ballot.

2. Voter Claims a Different Party Affiliation or Whose Party Does Not Have a Ballot (Primary Election Only)

These are voters who claim a party affiliation that is different than what is indicated in the electronic pollbook or who want to vote a ballot that is not for the party indicated in the electronic pollbook (this includes voters whose party does not have a ballot for the primary election).

- If a voter insists on voting a ballot for a party that is different from the one for the party affiliation shown in the electronic pollbook, or if the voter's party does not have a ballot for the primary election, he or she must vote a provisional ballot. **Use provisional code 3.**

3. Voter's Status is “Pend1”, “Pend2”, “ABS Issued”, or “Voted Early”

- A. **Pend 1**: The voter may only be issued a **provisional ballot**. The voter's driver's license number or social security number could not be verified. **Use provisional code 6.**

- The voter can present acceptable ID now or to the local board of elections before the

canvassing of provisional ballots which begins on the 2nd Wednesday after the election to complete the voter registration.

The screenshot shows a web-based interface for a voter record. At the top, the name 'Madison James' and address '7 Main St Anytown 12345' are displayed. Below this are tabs for 'Voter Details', 'Identification', 'Voter History', and 'Precinct Details'. A prominent red message box states: 'This voter can only vote a Provisional Ballot. This voter must show a form of ID to the Provisional Ballot Judge. Use reason code 6'. The voter's details include Precinct '001-001-1', DOB '4/25/1940', Party 'Green', Registered name 'Madison, James', ID Require 'Show ID', and Issued 'None'. The Status is 'Pend1', which is circled in red. At the bottom, there is a button labeled 'Issue Provisional Ballot' (also circled in red) and a 'Go Back' button. The footer shows 'BT:???:AC:Online', voting statistics (DEM 0, REP 0, NON 0, TOT 0), and the date/time '12/12/2013 12:11:41 PM'.

B. **Pend 2:** The voter may only be issued a **provisional ballot**. The voter's driver's license number or the last four digits of his or her social security number was not provided by the voter during registration. **Use provisional code 7.**

- If the voter provides either a Maryland driver's license number or the last four digits of his or her social security number, and if the local board of elections can verify the information on the Provisional Ballot Application, the ballot may be counted.
- If the voter has never been issued a Maryland driver's license or a social security number, the voter will be registered to vote and the ballot may be counted.
- If the voter does not provide either a verifiable Maryland driver's license number or last four digits of his or her social security number

before the canvassing deadline, the voter will not be registered to vote and the ballot will not be counted.

Voter Record 260

Monroe James 8 Main St Anytown 12345

Voter Details | Identification | Voter History | Precinct Details

This voter can only vote a Provisional Ballot. This voter must provide a Driver's License # or Social Security # on the Provisional Ballot Application.
Use reason code 7

Precinct 001-001-1 DOB 3/18/1901 Status **Pend2**

Registered name: Monroe, James Party Libertarian

ID Require **Need DL#-SSN#** Issued None

Comments
CONG=03; LEGIS=32; COUNCIL=001

Issue Provisional Ballot Go Back

BT:??? AC:Online Voted: DEM 0 REP 0 NON 0 TOT 0 12/12/2013 12:12:12 PM

C. **“ABS Issued”**: The voter may only be issued a provisional ballot. The voter has been issued an absentee ballot. Use provisional code 4.

Voter Record 260

Harrison William Henry 9 Main St Anytown 12345

Voter Details | Identification | Voter History | Precinct Details

This voter has been issued an absentee ballot. If the voter wants to cast a ballot now, he or she must vote by provisional ballot.
Enter "4" on the "Enter Provisional Reason" screen.

Precinct 001-001-1 DOB 2/16/1819 Status **Active ABS Issued**

Registered name: Harrison, William Henry Party Unaffiliated

ID Require Issued None

Comments
CONG=03; LEGIS=32; COUNCIL=001

Issue Provisional Ballot Go Back

BT:??? AC:Online Voted: DEM 0 REP 0 NON 0 TOT 0 12/12/2013 12:12:41 PM

- D. **Voted Early**: The voter may only be issued a **provisional ballot**. The voter has voted during early voting. **Use provisional code 4.**

Voter Record 260

Adams
John Quincy 10 Main St
Anytown 12345

Voter Details | Identification | Voter History | Precinct Details

This voter is flagged as "Voted Early." If the voter wants to cast a ballot now, he or she must vote by provisional ballot.
Enter "4" on the "Enter Provisional Reason" screen.

Precinct 001-001-1 DOB 3/16/1800 Status **Voted Early**

Registered name: Adams, John Quincy Party Other Parties Issued None

ID Require

Comments
CONG=03; LEGIS=32; COUNCIL=001

Issue Provisional Ballot Go Back

BT:?? AC:Online Voted: DEM 0 REP 0 NON 0 TOT 0 12/12/2013 12:13:03 PM

4. Inactive Status Voters ("ID Required" box is blank)

Voter Record 260

Jefferson
Thomas 5 Main St
Anytown 12345

Voter Details | Identification | Voter History | Precinct Details

This voter is "Inactive."
Issue a standard ballot if:
The voter's address is correct, or

Precinct 001-001-1 DOB 09/20/1830 Status Inactive

=Voter Ball 2 Party Democrat Issued None

Registered name: ID Required

Comments
CONG=03; LEGIS=32; COUNCIL=001

Issue Standard Ballot Issue Provisional Ballot Go Back

BT:?? AC:Plugged In Voted: TOT 2 11/19/2015 4:14:10 PM

Issue a regular ballot, not a provisional ballot, to Inactive Status voters when:

- The voter did not move and signs the Affirmation of Residency for Inactive Voter. The affirmation is automatically printed on the voter authority card for "Inactive" status voters when a regular ballot is issued; or
- The voter moved within 21 days of election day. The voter must complete a *Voter Update Form* and must sign the Affirmation of Residency for Inactive Voter on the voter authority card.

Affirmation of Residency for Inactive Voters

VOTER AUTHORITY CARD
2017 City of Annapolis Primary Election

Jefferson, Thomas
5 Main St., Annetown 12345
DOB: 8/20/1890
ID#: 0
Party: DEM
WARD: 001-001-1 CONG:03: LEGIS:32: COUNCIL:001
EPB Number:007189

Ballot Style:

Issued: 02/18/2017 16:02:27 Issued By: JOHN S
Issuing Consolidation: 02001001
Reason: 0

++AFFIRMATION OF RESIDENCY FOR INACTIVE VOTER++
I hereby affirm, under penalty of perjury, that
the address printed above or the address I provided on
the Voter Update Form is my current residence address.
Please sign in the space below.

Voter Signature _____

Check-In Judge Initials: _____

Ballot Issuing Judge: _____ Voting Judge: _____

DO NOT REMOVE THIS CARD FROM THE POLLING PLACE.



If the voter refuses to sign the affirmation of residency, alert a chief judge immediately.

Issue a provisional ballot to Inactive Status Voters when:

- The voter moved more than 21 days prior to election day.

Use provisional code 2.



The Affirmation of Residency will not print on the voter authority card for provisional voters.

5. “Issued” Box is “Reg Issued” or “PROV”

The pollbook indicates that the voter has been previously issued a ballot. Inform the voter that he or she is marked as having already been issued a ballot.

A. Reg Issued:

- If it can be confirmed that the voter’s ballot has not been cast, a regular ballot, not a provisional ballot, may be reissued by a chief judge. See *Chapter 5 – Chief Judges* for instructions. **Only chief judges can reissue a ballot.**

- If the ballot has been cast, or it is uncertain if the ballot has been cast, the voter may only be issued a provisional ballot. **Use provisional code 4.**

B. **PROV: Provisional ballot issued:** A voter who is checking-in whose status is “Prov”, and who insists that he or she has not voted or attempted to vote, **may only be issued a provisional ballot by a chief judge** (a supervisor password is required).



If the voter insists that he or she has not voted or attempted to vote, alert a chief judge immediately. The chief judge can contact the local board of elections for additional instructions.



All voters, regular and provisional, who make a mistake while voting their ballot (spoiled ballot) do not need to be checked-in at the pollbook again to receive a replacement ballot.

6. ID Require – Show ID (Active or Inactive)

If an “Active” or “Inactive” voter is listed as “Show ID,” ask the voter for ID.

- If the voter presents acceptable ID (see the chart below), issue the voter a regular ballot. A *Voter Update Form* must be completed to record this information.
- If the voter does not present an acceptable ID, issue the voter a provisional ballot. **Use provisional code 5.**

Voter Record 260

Adams John 6 Main St
Anytown 12345

Voter Details | Identification | Voter History | Precinct Details

This voter is "Inactive – ID Required."
 If the voter presents acceptable ID, a Voter Update Form must be completed to record the ID information.
 Issue a TS ballot if:

Precinct: 001-001-1 DOB: 06/15/1901 Status: **Inactive-IDrequired**

Registered name: _____ Party: Republican REC Issued: None

ID Required Show ID

Comments
CONG=03; LEGIS=32; COUNCIL=001

BT: ??? AC: Plugged In
Voted: TOT 1
11/20/2015 11:33:02 AM

Standards for Acceptable Forms of ID

<p>A “current” photo ID is an ID that has not expired</p> <p>A “current” non-photo ID is dated within 3 months of election day</p>	<p>Does the voter’s name on the ID have to match the electronic pollbook or the new name on the <i>Voter Update Form</i>?</p>	<p>Does the voter’s address on the ID have to match the electronic pollbook or the new address on the <i>Voter Update Form</i>?</p>
A current Maryland driver’s license	Yes	No
A current MVA-issued photo ID card	Yes	No
A current student photo ID card	Yes	No
A current employee photo ID card	Yes	No
A current military photo ID card	Yes	No
A current passport	Yes	No
Other current State or federal-issued photo ID card	Yes	No
A current utility bill [gas, electricity, water, waste, cable, telephone (land line or cell phone)]	Yes	Yes
A current bank statement	Yes	Yes
A current government check	Yes	Yes
A current paycheck	Yes	Yes
Other current government document	Yes	Yes

Standards for Unacceptable Forms of ID

An out-of-state driver's license	Not Acceptable
An expired photo ID card	Not Acceptable
Any non-photo ID that is more than 3 months old	Not Acceptable
A membership card (Sam's Club, gym etc.)	Not Acceptable
A Voter Notification Card	Not Acceptable
A Social Security Card	Not Acceptable
Any non-photo ID with an address that does NOT match the electronic pollbook or the new address on the <i>Voter Update Form</i>	Not Acceptable

Reprinting a Voter Authority Card

If the printer paper tears or jams as the voter authority card is being printed, use the printer "Reprint" button to reprint the same voter authority card:

1. Press the green "Feed" button on the printer and carefully remove the torn or jammed paper; and
2. Press the blue "Reprint" button to print another copy of the voter's voter authority card.

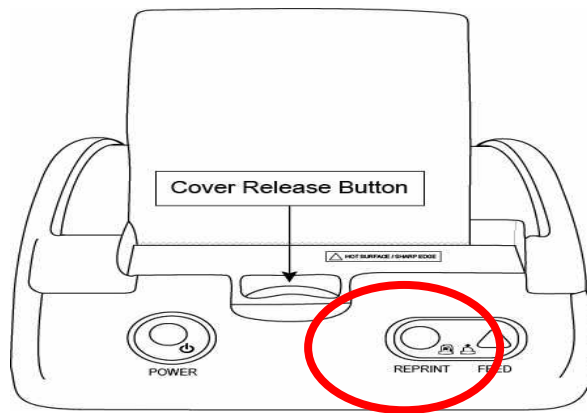

3. If another voter authority card does not print when the “Reprint” button is pressed, the electronic pollbook can be used to reprint a voter authority card for any voter who has been issued a ballot.
 - From the Voter Record screen, tap on the “Identification” tab at the top; and
 - Tap on the “Reprint VAC” button in the lower left corner.

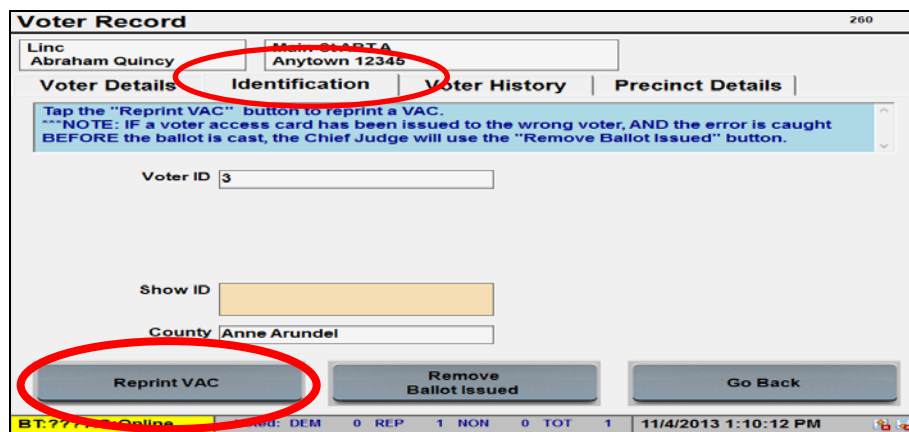

Resetting the Judge’s Name

The first time you attempt to issue a ballot, you will be prompted to enter your name. Type in the first initial of your first name and then your last name with no spaces. Tap “OK” to continue. You will not have to enter your name or initials to issue ballots again unless the judge’s name on the electronic pollbook has been reset. To reset the judge’s name:

4. Tap the “Reset Judge’s Name” button.

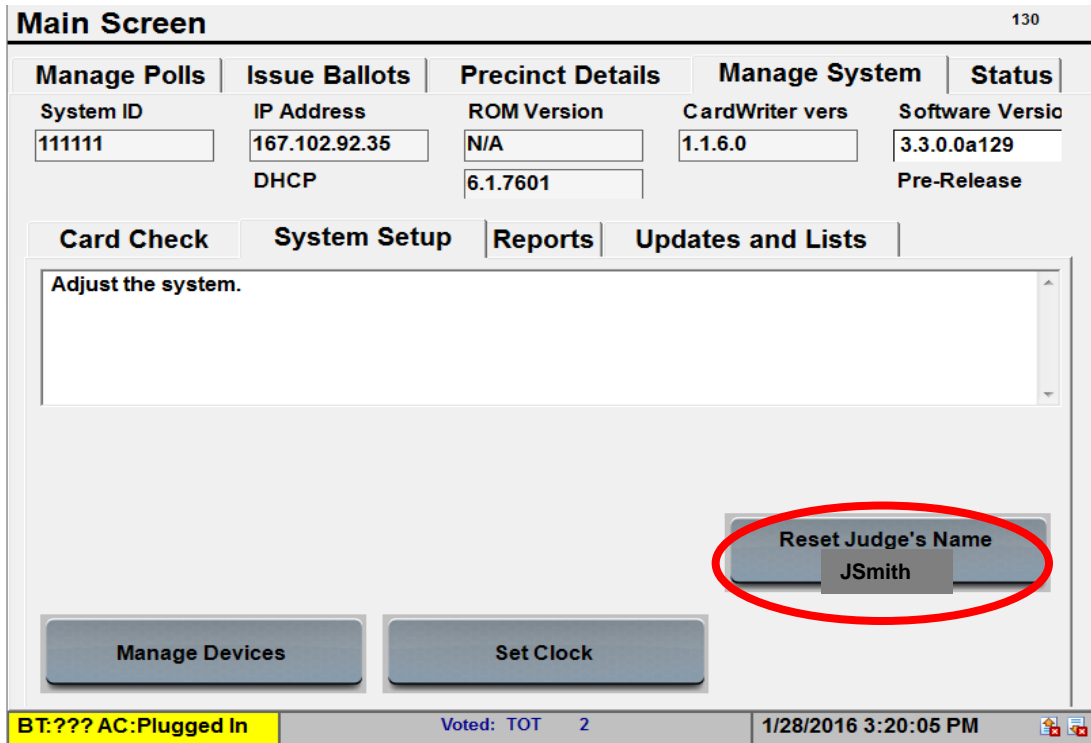

5. The election judge’s name in the electronic pollbook will be reset. Tap “Issue Ballots” tab to continue to issue ballots. The election judge will be prompted to enter his or her name before the next ballot can be issued.

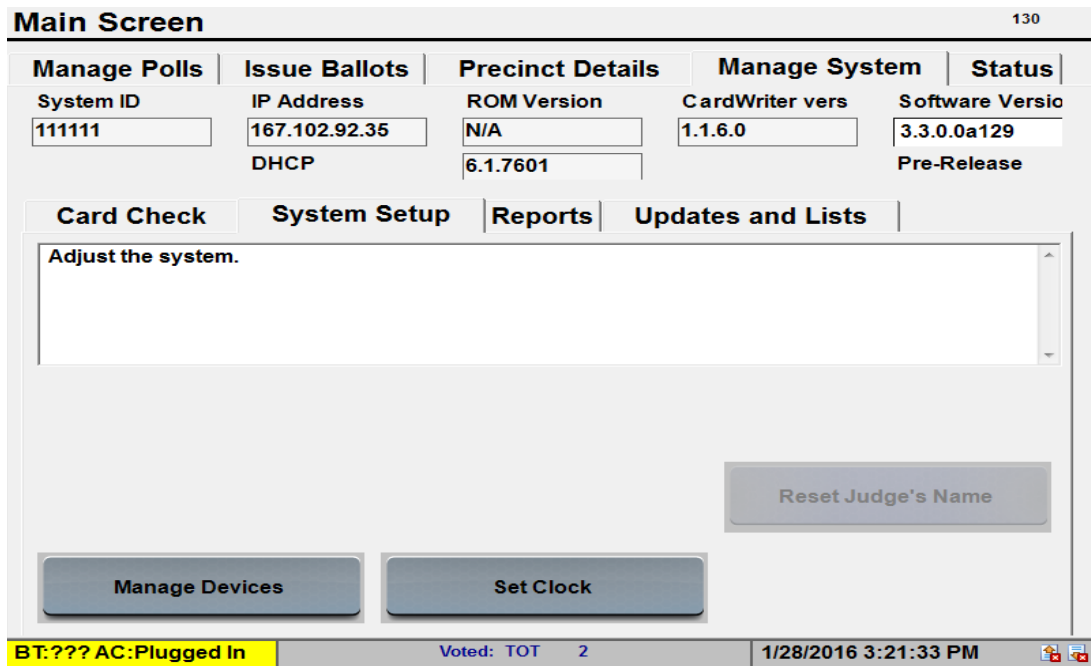

Ending the Election

After providing all necessary voter turnout numbers to the chief judges, and **upon authorization from the chief judges**, the check-in judges are to:

1. Return to the “Main Screen” and tap the “Manage Polls” tab.
2. Tap on the “Daily Closing Step #1 Close the Polls” button at the bottom center of the screen. A pop-up screen will appear.

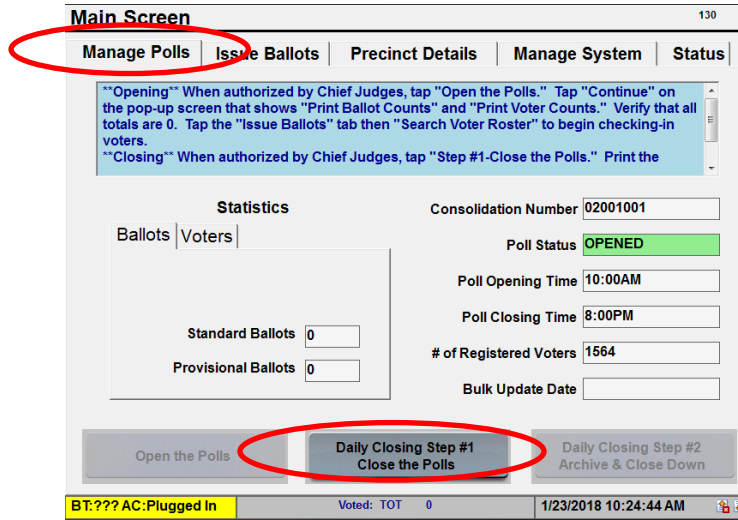

3. Tap the “Continue” button to print the Ballots Counts and Voter Counts reports.

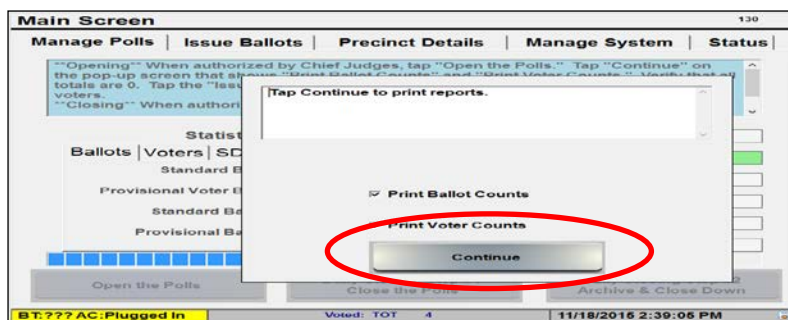

 After the “Continue” button is tapped, the “Poll Status” changes from “Opened” to “Closed.”

4. Tap “Yes” at the “Continue Closing the Polls?” prompt.

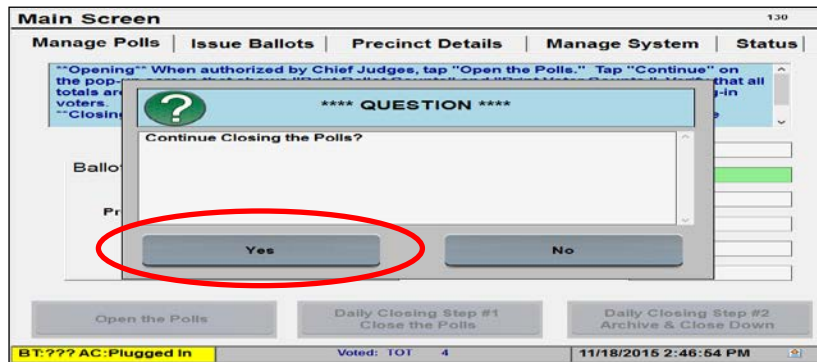

5. After the Ballot Counts and Voter Counts reports are printed, tap the “Daily Closing Step #2 Archive & Close Down” button.

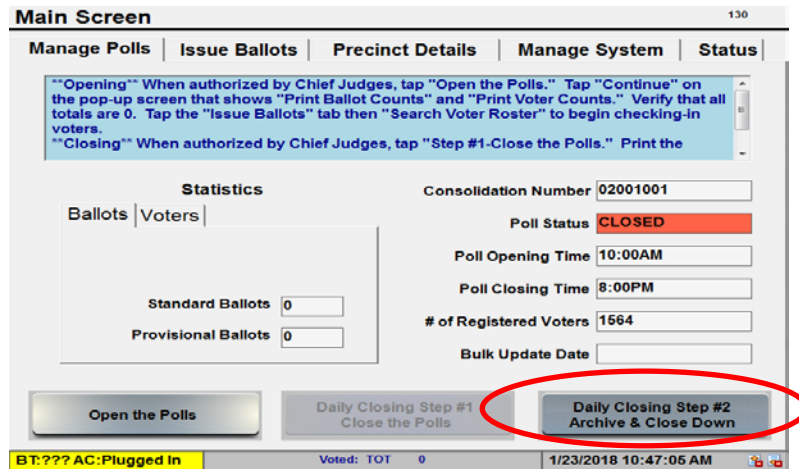

6. If the polling place is closed for the day, **and** if the end of day Ballot Counts and Voter Counts reports have been printed, tap the “Yes” button at the “Question” prompt.

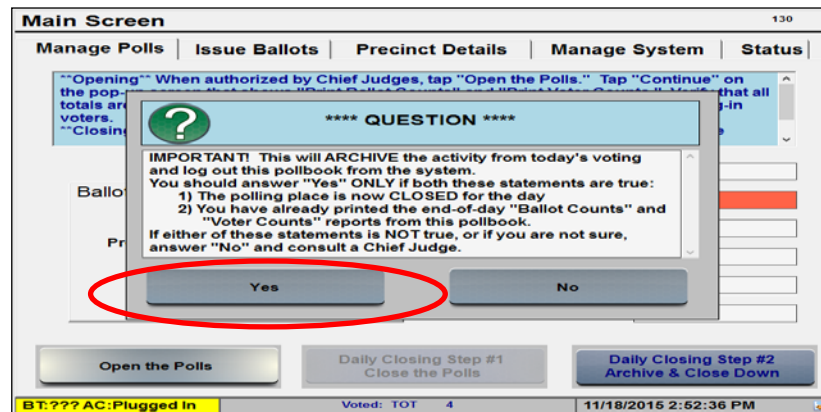

7. The electronic pollbook will return to the “Launch” screen. Turn the power switch to OFF.

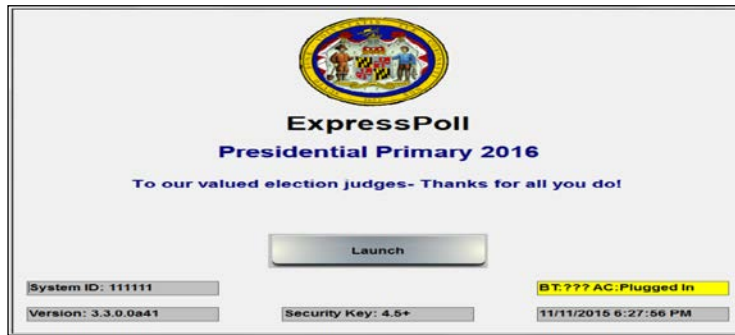

8. When removing the two compact flash (CF) cards from each electronic pollbook:
- Break the red inner seal and place it in the clear zipper bag.
 - Remove the top lid from pollbook as demonstrated in training.
 - Remove the the two compact flash cards (press the small black button beside each) and place the cards in the clear zipper bag. There will be 2 compact flash cards removed per pollbook at your polling place.
 - Replace the lid on the top of the electronic pollbook.

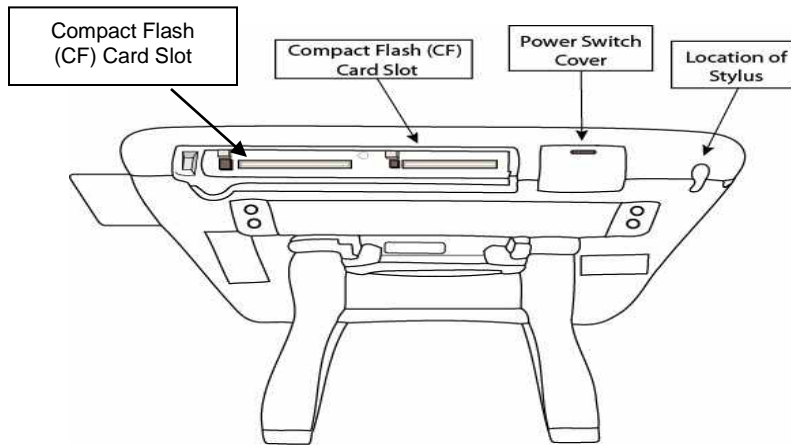

9. Chief judges must sign the *Consolidated Ballot Counts Report* and the *Consolidated Voter Counts Report*.

Consolidated Ballot Counts Report				
Poll Description: 05-1 Mt Vernon Fire Dept				
Report Date: 04/12/2010 14:49:00				
	TOT	DEM	REP	NON
Issued	303	149	110	44
Reiss	- 3	- 1	- 2	- 0
Canc	- 10	- 3	- 5	- 1
Net	290	145	102	43
Prov Issued	- 19	- 5	- 3	- 5
Prov Reiss	- 1	- 0	- 0	- 1
Prov Canc	- 1	- 1	- 0	- 0
Net Prov	- 17	- 7	- 3	- 7
Net Ballots	307	152	105	50
DEM Judge _____				
REP Judge _____				

! Reissued and cancelled ballots are **subtracted** from “Issued” ballots to arrive at “Net Ballots” totals for regular and provisional ballots.

! The total (“TOT”) of the *Consolidated Voter Counts Report* should equal “Net Ballots” on the *Consolidated Ballot Counts Report*.

Consolidated Voter Counts Report			
Consolidation: # 20005001 EPB Number: 999			
Poll Description: 05-1 Mt Vernon Fire Dept			
Report Date and Time: 04/12/2010 16:58:56			
	Total	Reg	Prov
PARTY			
DEM	152	145	7
REP	105	102	3
NON	50	43	7
TOT	307	290	17
DEM Judge _____			
REP Judge _____			

10. Give the Electronic Pollbook Integrity Report (with the attached reports) to the chief judges.

Packing the Electronic Pollbooks and Printers

1. Store the stylus in its slot at the top of each electronic pollbook.
2. Disconnect all cables and cords.
3. Pack the electronic pollbooks in their respective cases along with their power pack and cords.
4. Reattach original blue lock to the case for each packed pollbook. Record the new outer seal numbers on *Electronic Pollbook Integrity Report* (this number will be the same as when pollbook cases were originally opened the previous evening) and have both chief judges sign where indicated.
5. Pack all printers, power cords, USB cords and network cables within printer case(s). Pack printer case(s), pollbook cases and hub (if issued) within grey tote(s) as originally found. Pack printer case and any extra pollbook cases in the non-wheeled blue transfer case if provided. Don't forget to pack the sign totem on the bottom of grey tote.
6. Follow packing picture posted within transfer cart(s) as a guide for packing ALL voting equipment including the grey totes.